



Installation and Operation Instructions

Astria™ Unvented (Vent-Free) Peninsula Firebox with Flushed Face Ivory Stacked Liner

P/N 126688-01 Rev.A 02/2014



P126688-01



Models

TaurusPFZ2

INSTALLER: Leave this manual with the appliance.
CONSUMER: Retain this manual for future reference.

⚠ WARNING: Carefully review the instructions supplied with the decorative type unvented room heater for the minimum fireplace size requirement.

Do not install the appliance in this firebox, unless this firebox meets the minimum dimensions required for the installation.

⚠ WARNING: For use only with a listed, gas-fired unvented decorative room heater not to exceed 40,000 Btu/H.

Do not build a wood fire.

⚠ WARNING: If the information in these instructions is not followed exactly, a fire or explosion may result causing property damage, personal injury or loss of life.

- Do not store or use gasoline or other flammable vapors and liquids in the vicinity of this or any other appliance.
- **WHAT TO DO IF YOU SMELL GAS:**
 - Do not try to light any appliance.
 - Do not touch any electrical switch; do not use any phone in your building.
 - Immediately call your gas supplier from a neighbor's phone. Follow the gas supplier's instructions.
 - If you cannot reach your gas supplier, call the fire department.
- Installation and service must be performed by a qualified installer, service agency or the gas supplier.

⚠ WARNING: Improper installation, adjustment, alteration, service or maintenance can cause injury or property damage. Refer to this manual for correct installation and operational procedures. For assistance or additional information consult a qualified installer, service agency or the gas supplier.

TABLE OF CONTENTS

Safety	2	Operating Guidelines and Maintenance	
Local Codes.....	4	Instructions	14
Unpacking.....	4	Replacement Parts.....	15
Product Features	4	Technical Service.....	15
Product Specifications	5	Accessory	15
Locating Firebox	5	Parts	16
Air for combustion and Ventilation	6	Warranty	18
Installation	8		

SAFETY

This appliance may be installed in an aftermarket,* permanently located, manufactured (mobile) home, where not prohibited by local codes.

* Aftermarket: Completion of sale, not for purpose of resale, from the manufacturer

This firebox has been tested under Z21.91b-2007 for use with approved ANSI Z21.11.2 decorative type unvented room heater.

⚠ WARNING: Any change to this firebox or its controls can be dangerous.

⚠ WARNING: Do not use a blower insert, heat exchanger insert or other accessory not approved for use with this firebox.

IMPORTANT: Read this owner's manual carefully and completely before trying to assemble, operate or service this fireplace. Improper use of this fireplace can cause serious injury or death from burns, fire, explosion, electrical shock and carbon monoxide poisoning.

⚠ DANGER: Carbon monoxide poisoning may lead to death!

⚠ WARNING: Do not allow fans to blow directly into the firebox. Avoid any drafts that alter burner flame patterns. Ceiling fans can create drafts that alter burner flame patterns. Altered burner patterns can cause sooting.

SAFETY

Continued

Due to high temperatures, the appliance should be located out of traffic and away from furniture and draperies.

Do not place clothing or other flammable material on or near the appliance. Never place any objects in the firebox or on logs.

Firebox front and screen becomes very hot when running firebox. Keep children and adults away from hot surfaces to avoid burns or clothing ignition. Firebox will remain hot for a time after shutdown. Allow surfaces to cool before touching.

Carefully supervise young children when they are in the room with firebox.

Keep the fireplace area clear and free from combustible materials, gasoline, and other flammable vapors and liquids.

You must operate this fireplace with the provided fireplace screen and hood in place. Make sure these parts are in place and screens are closed before running installed gas log heater. Replace hood with INNOVATIVE HEARTH PRODUCTS model 109511-01 50", 109511-02 42", or 109511-03 36" only. This hood has been designed to keep the operation of your fireplace safe and efficient.

1. This firebox shall not be installed in a bedroom or bathroom.
2. Never install the firebox
 - in a recreational vehicle
 - where curtains, furniture, clothing or other flammable objects are less than 42" from the front, top or sides of the firebox
 - in high traffic areas
 - in windy or drafty areas
3. Do not use this firebox as a wood-burning fireplace. Use only decorative unvented room appliances (log sets).
4. Do not add extra logs or ornaments such as pine cones, vermiculite or rock wool. Using these added items can cause sooting.
5. Use only the provided hoods accessories. See *Accessories* on page 17.
6. Vent-free gas log appliances installed in this firebox require fresh air ventilation to run properly. See *Air for Combustion and Ventilation*, page 6.
7. Do not run firebox
 - where flammable liquids or vapors are used or stored
 - under dusty conditions
8. Do not use this firebox to cook food or burn paper or other objects.
9. Never place any objects in firebox or on logs.
10. Turn firebox off and let cool before servicing. Only a qualified service person should service and repair firebox.
11. Operating vent-free logs in a firebox above elevations of 4,500 feet could cause pilot outage.
12. Do not use the firebox if it has been under water due to the shock hazard that could result with the blower accessory (if installed) in place.
13. Provide adequate clearances around air openings.

The firebox canopy (hood) must not be modified or replaced with a canopy (hood) that may be provided with the unvented decorative room heater.

LOCAL CODES

Install and use firebox with care. Follow all local codes. In the absence of local codes, use the latest edition of *The National Fuel Gas Code ANS Z223.1/NFPA 54**. Firebox must be electrically grounded in accordance with the *National Electrical Code, ANS/NFPA70* (latest edition).

*Available from:

American National Standards Institute, Inc.
1430 Broadway
New York, NY 10018

National Fire Protection Association, Inc.
Batterymarch Park
Quincy, MA 02269

State of Massachusetts: The installation must be made by a licensed plumber or gas fitter in the Commonwealth of Massachusetts.

Sellers of unvented propane or natural gas-fired supplemental room appliances shall provide to each purchaser a copy of 527 CMR 30 upon sale of the unit.

Vent-free gas products are prohibited for bedroom and bathroom installation in the Commonwealth of Massachusetts.

UNPACKING

1. Remove all protective packaging from inside firebox. Carefully lift the firebox off the bottom corrugated tray.
2. Carton should contain 3 deflective hoods and hardware packet in addition to firebox assembly. If items are missing, inform dealer where you bought firebox.
3. Check appliance for any shipping damage. If appliance is damaged call INNOVATIVE HEARTH PRODUCTS at 1-800-655-2008 for replacement parts before returning to dealer.

NOTICE: The firebox identification label (including model number, serial number, clearances, etc.) is located directly above the brick liner and under the heat shield. See Figure 20, page 16.

PRODUCT FEATURES

OPERATION

This firebox is designed for use with approved ANS Z21.11.2 decorative type unvented room appliances. (Physical size limitations apply. Refer to minimum firebox requirements supplied with log appliance.) The maximum size log this firebox will accept is: width of 32", depth of 19" and a height of 17".

This firebox requires no outside venting or chimney making installation easy and inexpensive. When used without the blower, the firebox requires no electricity making it ideal for emergency backup heat.

BLOWER ACCESSORY

The firebox will accept the GA3500A accessory. The variable blower allows you to select the fan speed you desire. The blower circulates heated air from the firebox into the room. Use of blower is optional.

BRICK LINER

This firebox features a concrete brick liner. As with all concrete liners, this liner may develop slight cracks when exposed to heat. These cracks will not affect the performance of the firebox or vent-free gas logs.

PRODUCT SPECIFICATIONS

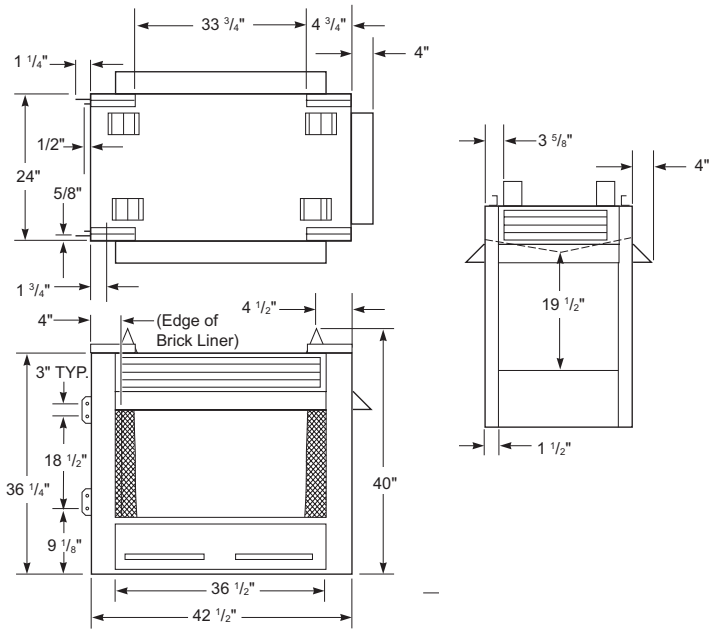

Figure 1 - Peninsula (Three-Sided) Firebox

LOCATING FIREBOX

PLANNING

Plan where you will install the firebox. This will save time and money later when you install the firebox. Before installation, consider the following:

1. Where the firebox will be located. Allow for wall and ceiling clearances (see *Installation Clearances*, page 9).
2. Everything needed to complete installation.
3. This model CANNOT be installed in a bedroom or bathroom.
4. Proper air for combustion and ventilation.
5. Consider a location where heat output would not be affected by drafts, air condition ducts, windows or doors.
6. A location that minimizes modifications on existing framing will make installation easier.

Projected installations can extend any distance into the room. A projection may be ideal as a partition between two oth-

erwise common areas when added to an existing, finished wall (see Figure 2).

Internal wall installation provides a discreet viewing option between two adjacent rooms or within an added wall to subdivide an oversize room.

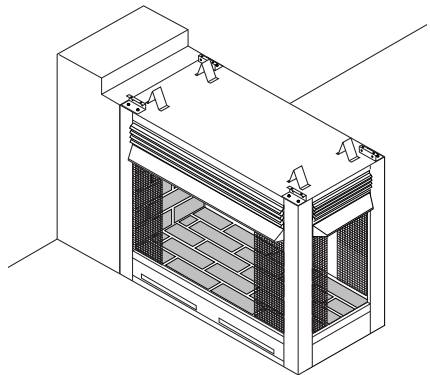

Figure 2 - Projected Installation

AIR FOR COMBUSTION AND VENTILATION

⚠ WARNING: This appliance shall not be installed in a room or space unless the required volume of indoor combustion air is provided by the method described in the *National Fuel Gas Code, ANSI Z223.1/NFPA 54, the International Fuel Gas Code, or applicable local codes. Read the following instructions to insure proper fresh air for this and other fuel-burning appliances in your home.*

Today's homes are built more energy efficient than ever. New materials, increased insulation and new construction methods help reduce heat loss in homes. Home owners weather strip and caulk around windows and doors to keep the cold air out and the warm air in. During heating months, home owners want their homes as airtight as possible.

While it is good to make your home energy efficient, your home needs to breathe. Fresh air must enter your home. All fuel-burning appliances need fresh air for proper combustion and ventilation.

Exhaust fans, fireboxes, clothes dryers and fuel burning appliances draw air from the house to operate. You must provide adequate fresh air for these appliances. This will insure proper venting of vented fuel-burning appliances.

PROVIDING ADEQUATE VENTILATION

The following are excerpts from *National Fuel Gas Code ANS Z223.1/NFPA 54, Air for Combustion and Ventilation*.

All spaces in homes fall into one of the three following ventilation classifications:

1. Unusually Tight Construction
2. Unconfined Space
3. Confined Space

The information on pages 6 through 8 will help you classify your space and provide adequate ventilation.

Unusually Tight Construction

The air that leaks around doors and windows may provide enough fresh air for combustion and ventilation. However, in buildings of unusually tight construction, you must provide additional fresh air.

Unusually tight construction is defined as construction where:

- a. walls and ceilings exposed to the outside atmosphere have a continuous water vapor retarder with a rating of one perm (6×10^{-11} kg per pa-sec- m^2) or less with openings gasketed or sealed and
- b. weather stripping has been added on openable windows and doors and
- c. caulking or sealants are applied to areas such as joints around window and door frames, between sole plates and floors, between wall-ceiling joints, between wall panels, at penetrations for plumbing, electrical and gas lines and at other openings.

If your home meets all of the three criteria above, you must provide additional fresh air. See Ventilation Air From Outdoors, page 8.

If your home does not meet all of the three criteria above, proceed to Determining Fresh-Air Flow for Firebox Location, page 7.

Confined and Unconfined Space

The *National Fuel Gas Code ANS Z223.1/NFPA 54* defines a confined space as a space whose volume is less than 50 cubic feet per 1,000 Btu/hr (4.8 m³ per kw) of the aggregate input rating of all appliances installed in that space and an unconfined space as a space whose volume is not less than 50 cubic feet per 1,000 Btu/hr (4.8 m³ per kw) of the aggregate input rating of all appliances installed in that space. Rooms communicating directly with the space in which the appliances are installed*, through openings not furnished with doors, are considered a part of the unconfined space.

This appliance shall not be installed in a confined space or unusually tight construction unless provisions are provided for adequate combustion and ventilation air.

* Adjoining rooms are communicating only if there are doorless passageways or ventilation grills between them.

AIR FOR COMBUSTION AND VENTILATION

Continued

DETERMINING FRESH-AIR FLOW FOR FIREBOX LOCATION

Determining if You Have a Confined or Unconfined Space

Use this work sheet to determine if you have a confined or unconfined space.

Space: Includes the room in which you will install appliance plus any adjoining rooms with doorless passageways or ventilation grills between the rooms.

1. Determine the volume of the space (length x width x height).

Length x Width x Height = _____ cu. ft.
(volume of space)

Example: Space size 22 ft. (length) x 18 ft. (width) x 8 ft. (ceiling height) = 3168 cu. ft. (volume of space)

If additional ventilation to adjoining room is supplied with grills or openings, add the volume of these rooms to the total volume of the space.

2. Multiply the space volume by 20 to determine the maximum Btu/Hr the space can support.

_____ (volume of space) x 20 = (Maximum Btu/Hr the space can support)

Example: 3168 cu. ft. (volume of space) x 20 = 63,360 (maximum Btu/Hr the space can support)

3. Add the Btu/Hr of all fuel burning appliances in the space.

Gas water appliance* _____ Btu/Hr

Gas furnace _____ Btu/Hr

Vented gas appliance _____ Btu/Hr

Gas fireplace logs _____ Btu/Hr

Other gas appliances* + _____ Btu/Hr

Total = _____ Btu/Hr

* Do not include direct-vent gas appliances. Direct-vent draws combustion air from the outdoors and vents to the outdoors.

Example:

Gas water appliance 40,000 Btu/Hr

Gas firebox logs + 39,000 Btu/Hr

Total = 79,000 Btu/Hr

4. Compare the maximum Btu/Hr the space can support with the actual amount of Btu/Hr used.

_____ Btu/Hr (maximum the space can support)

_____ Btu/Hr (actual amount of Btu/Hr used)

Example: 63,360 Btu/Hr (maximum the space can support)

79,000 Btu/Hr (actual amount of Btu/Hr used)

The space in the above example is a confined space because the actual Btu/Hr used is more than the maximum Btu/Hr the space can support. You must provide additional fresh air. Your options are as follows:

- A. Rework work sheet, adding the space of an adjoining room. If the extra space provides an unconfined space, remove door to adjoining room or add ventilation grills between rooms. See *Ventilation Air from Inside Building*, page 8.
- B. Vent room directly to the outdoors. See *Ventilation Air from Outdoors*, page 8.
- C. Install a lower Btu/Hr gas log appliance, if lower Btu/Hr size makes room unconfined.

If the actual Btu/Hr used is less than the maximum Btu/Hr the space can support, the space is an unconfined space. You will need no additional fresh air ventilation.

⚠ WARNING: If the area in which the appliance may be operated does not meet the required volume for indoor combustion air, combustion and ventilation air shall be provided by one of the methods described in the *National Fuel Gas Code, ANSI Z223.1/NFPA 54*, the *International Fuel Gas Code*, or applicable local codes.

AIR FOR COMBUSTION AND VENTILATION

Continued

VENTILATION AIR

Ventilation Air From Inside Building

This fresh air would come from an adjoining unconfined space. When ventilating to an adjoining unconfined space, you must provide two permanent openings: one within 12" of the ceiling and one within 12" of the floor on the wall connecting the two spaces (see option 1, Figure 3). You can also remove door into adjoining room (see option 2, Figure 3). Follow the *National Fuel Gas Code ANS Z223.1/NFPA 54 Air for Combustion and Ventilation* for required size of ventilation grills or ducts.

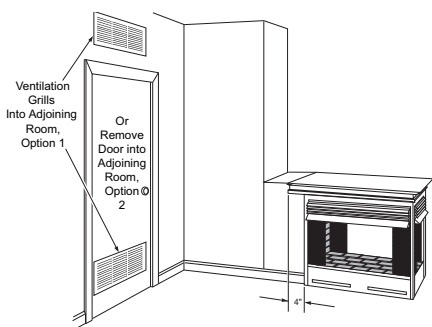

Figure 3 - Ventilation Air from Inside Building

Ventilation Air From Outdoors

Provide extra fresh air by using ventilation grills or ducts. You must provide two permanent openings: one within 12" of the ceiling and one within 12" of the floor. Connect these items directly to the outdoors or spaces open to the outdoors. These spaces include attics and crawl spaces. Follow the *National Fuel Gas Code ANS Z223.1/NFPA 54 Air for Combustion and Ventilation* for required size of ventilation grills or ducts.

IMPORTANT: Do not provide openings for inlet or outlet air into attic if attic has a thermostat-controlled power vent. Heated air entering the attic will activate the power vent.

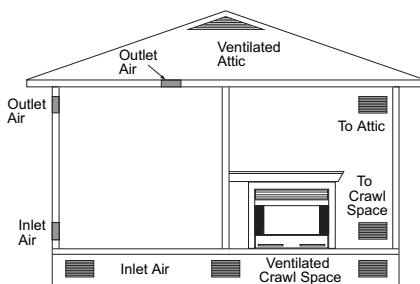

Figure 4 - Ventilation Air from Outdoors

INSTALLATION

NOTICE: This firebox in combination with unvented log sets are intended for use as supplemental heat. Use along with your primary heating system. Do not install them as your primary heat source. If you have a central heating system, you may run system's circulating blower while using appliance. This will help circulate the heat throughout the house. In the event of a power outage, you can use unvented logs as your primary heat source.

WARNING: A qualified service person must install firebox. Follow all local codes.

WARNING: Never install the firebox

- in a bedroom or bathroom
- in a recreational vehicle
- where curtains, furniture, clothing or other flammable objects are less than 42" from the front, top or sides of the firebox
- in high traffic areas
- in windy or drafty areas

INSTALLATION

Continued

⚠ CAUTION: Log appliances installed in this firebox create warm air currents. These currents move heat to wall surfaces next to firebox. Installing firebox next to vinyl or cloth wall coverings or operating firebox where impurities (such as, but not limited to, tobacco smoke, aromatic candles, cleaning fluids, oil or kerosene lamps, etc.) in the air exist, may discolor walls or cause odors.

IMPORTANT: Vent-free gas log appliances add moisture to the air. Although this is beneficial, installing firebox in rooms without enough ventilation air may cause mildew to form from too much moisture. See [Air for Combustion and Ventilation](#), page 6.

IMPORTANT: Make sure the firebox is level. If firebox is not level, log set will not work properly.

Note: Your Vanguard firebox is designed to be used in zero clearance installations. Wall or framing material can be placed against any exterior surface on the rear, sides or top of your firebox, except where standoff spacers are integrally attached. If standoff spacers are attached to your firebox, these spacers can be placed directly against wall or framing materials.

Use dimensions shown for rough openings to create the easiest installation (see [Built-In or Internal Wall Firebox Installation](#), page 9).

INSTALLATION CLEARANCES

⚠ WARNING: Maintain the minimum clearances. If you can, provide greater clearances from floor, ceiling and adjoining wall.

Carefully follow the instructions below. This will ensure safe installation.

Minimum Wall and Ceiling Clearances

- Clearances from edge of liner to any combustible wall should not be less than 8" (see Figure 5).
- Clearances from top of firebox opening to the ceiling should not be less than 42".

- When the firebox is installed on carpeting or other combustible material, other than wood flooring, the firebox should be installed on a metal or wood panel extending the full width and depth of enclosure.
- Clearances from the bottom of firebox to the floor is 0".
- Clearances from open end of firebox to facing wall shall should not be less than 36".

⚠ CAUTION: Do not install firebox directly on carpet or vinyl.

⚠ CAUTION: Use only the clearances specified in this manual or on the firebox rating plate.

Minimum clearances to combustibles are:

- Sides of outer casing 0" min.
- Drywall to sides and top of front face 0" min.
- Ceiling to opening 42' min.
- Floor (see [Minimum Wall and Ceiling Clearances](#), note C) 0" min.
- Perpendicular walls Right and Left 4' min.
- Distance to Facing Walls on Sides and End of Firebox 36" min.

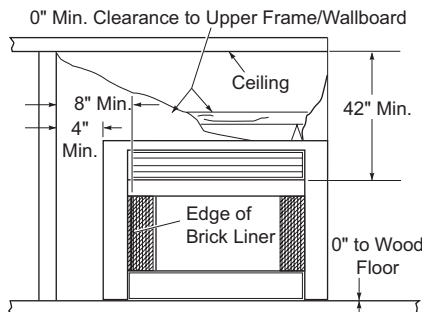

Figure 5 - Minimum Clearance Front View

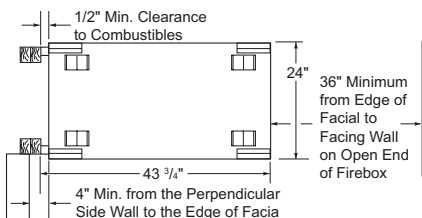

Figure 6 - Minimum Clearance - Top View

INSTALLATION

Continued

Mantel Clearances for Built-In Installation

If placing custom mantel above built-in firebox, you must meet the minimum allowable clearance between mantel shelf and top of firebox opening shown in Figure 7. These are the minimum allowable mantel clearances for a safe installation. Use larger clearances wherever possible to minimize the heating of objects and materials placed on the mantel.

⚠ CAUTION: Do not allow the vent-free gas log appliance to touch or extend beyond the firebox screen.

If your installation does not meet the above minimum clearances in Figure 7, you must:

- raise the mantel to an acceptable height,
- OR
- remove the mantel.

Wall board or facing material (above firebox) may be of combustible material, including decorative mantel ornaments or other similar projections off of the facing material.

measurements are minimum distances from top of fireplace hood to bottom of mantel shelf. These minimum clearances replace any other recommended clearances supplied with your ANS Z21.11.2 approved gas logs.

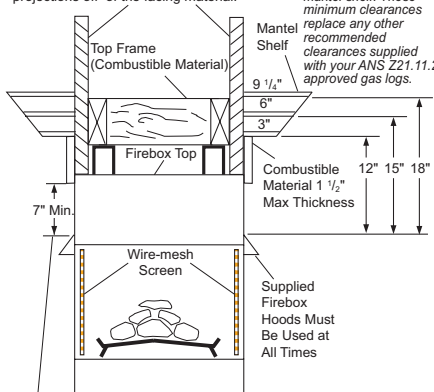

Note: Fireplace shown as cross-section for clarity. Mantel material may not be less than 7" from top of hood. Do not cover louver openings.

Figure 7 - Minimum Mantel Clearances for Built-In Installation

BUILT-IN OR INTERNAL WALL FIREBOX INSTALLATION

Built-in installation of this firebox involves installing firebox into a framed-in enclosure. This makes the front of firebox flush with wall. If installing a mantel above the firebox, you must follow the clearances shown in Figure 7. Follow the instructions below to install the

firebox in this manner.

1. Frame in rough opening. The firebox framing should be constructed of 2 x 4 lumber or heavier. Construct framing using dimensions shown in Figure 8 and 9, page 11. It is recommended that the framing be constructed first and the unit be placed in position. After sliding the unit into place, the flanges may be nailed to the framing before applying the wallboard to the exterior framing.
2. If the vent-free firebox is to be installed directly on carpeting, tile (other than ceramic) or any combustible material other than wood flooring; the vent-free firebox must be installed upon a metal or wood panel extending the full width and depth of the vent-free firebox.
3. If a raised platform is to be constructed, ceiling clearances must be maintained.
4. Install gas piping to firebox location. See Installing Gas Line and Connecting to Gas Supply in log set owner's manual.
5. Carefully set firebox in front of rough opening.
6. Carefully insert firebox into rough opening.
7. Attach firebox to wall studs using nails or wood screws through holes in nailing flange (see Figure 10). Attach firebox to board base through holes in firebox bottom (see Figure 10).

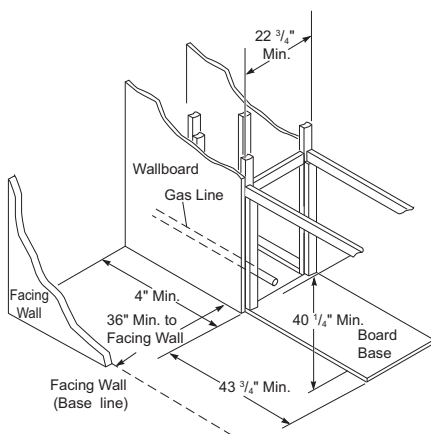

Figure 8 - Framing for Built-In Firebox Installation

INSTALLATION

Continued

IMPORTANT: When finishing your firebox, combustible materials such as wall board, gypsum board, sheet rock, drywall, plywood, etc. may be butted up next to the sides and top of the firebox. Combustible materials should never overlap the firebox front facing more than 3/8".

WARNING: Do not allow any combustible materials to overlap the firebox front facing (see Figure 9).

IMPORTANT: Noncombustible materials such as brick, tile, etc. may overlap the front facing, but should never cover any necessary openings like louvered slots.

WARNING: Never modify or cover the louvered slots on the front of the firebox.

WARNING: Use only non-combustible mortar or adhesives when overlapping the front facing with noncombustible facing material.

WARNING: Do not fill the spaces around the firebox with insulation or other materials.

WARNING: Framing may be placed or rest against fireplace spacer, however; framing must never be notched.

WARNING: Do not alter, cut or modify fireplace spacers.

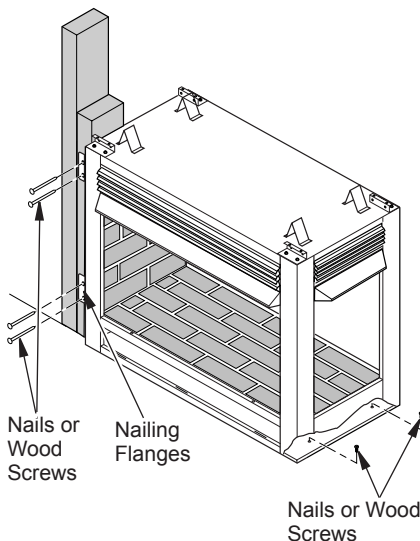

Figure 10 - Attaching Firebox to Wall Studs

INSTALLING GAS LINE

WARNING: A qualified service person must connect appliance to gas supply. Follow all local codes.

IMPORTANT: See *Connecting to Gas Supply* in your log set owner's manual for details on gas hookup.

Figure 11, page 12, shows the typical installation for the gas line. When you have determined how the gas line will run, locate one of the recessed knockouts in the firebrick floor (see Figure 12, page 12.). Firmly tap the center of the knockout with a chisel until it is released. Carefully chisel the rough edges of the hole you have made to smooth edges. This hole will line up with the hole in the metal floor.

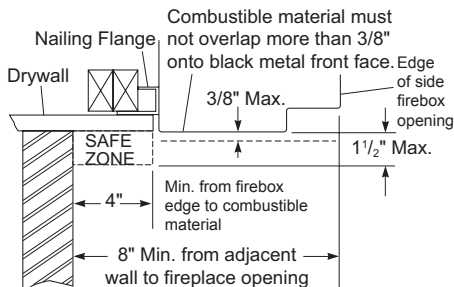

Figure 9 - Framing for Built-In Firebox Installation, Top View

INSTALLATION

Continued

CAUTION: Do not use excessive force to remove the knockout. Too much force may damage the firebrick concrete insert.

A manual shutoff valve, CSA certified and complying with the *National Fuel Gas code, ANS Z223.1/NFPA 54*, must be included within 6' of the vent-free firebox gas supply system. It may be convenient to install the gas shutoff outside the vent-free firebox enclosure where it can be accessed with a key through a wall as shown in Figure 13. Depending on the type of installation, some local codes may require you to install 2 manual shutoff valves independently accessible from both rooms. Check your local codes for applicable installation requirements.

A 36" long 1/2" NPT SCHD 40 flexible gas connector line complying with the *National Fuel Gas code ANS Z223.1/NFPA 54*, may be run from the regulator to the incoming 1/2" NPT black iron gas line. You may also route the incoming 1/2" NPT black iron gas line directly to the appliance regulator.

Remove the gas line cover plate from the vent-free firebox's outer surround and route

Gas Line Installed Through Access Hole on One Side of Firebox

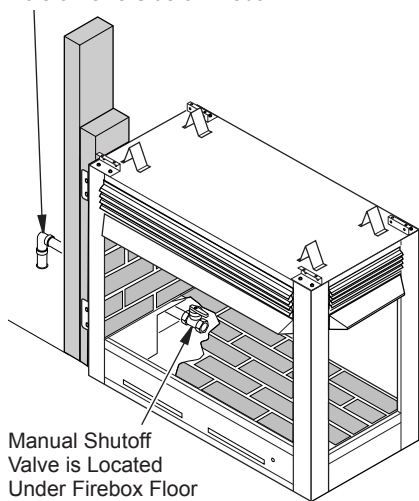

Figure 11 - Installing Gas Line and Manual Shutoff Valve

the gas line into the rear of the firebox (see Figure 11).

If a sediment trap (not supplied) is not incorporated as a part of the gas utilization equipment, one shall be installed as close to the inlet of the equipment as practical at the time of installation, as per *ANS Z223.1/NFPA 54*. See Figure 14.

Firebrick Floor

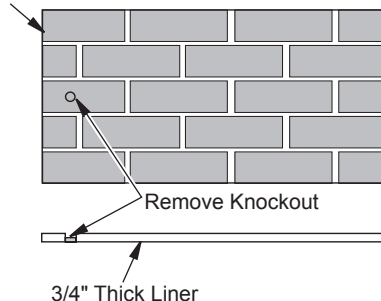

Figure 12 - Location of Knockouts for Gas Line

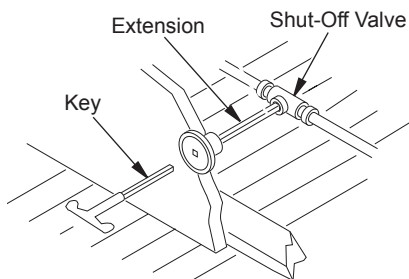

Figure 13 - Typical Exterior Wall Gas Shut-Off Installation

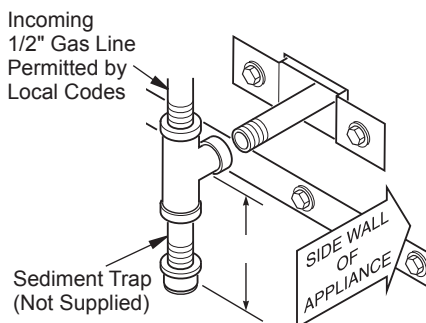

Figure 14 - Sediment Trap Installation

INSTALLATION

Continued

Prepare incoming black iron gas line with Teflon tape or pipe joint compound (check with local codes as to the use of Teflon tape). Compounds used on threaded joints of gas piping shall be resistant to the action of propane/LP and should be applied lightly to ensure excess sealant does not enter the gas line.

Complete your gas installation by connecting the incoming gas line to the appliance regulator. Secure all joints tightly with wrench but do not overtighten. If a flexible gas line is used, take care not to kink the connector.

WARNING: All gas piping and connections must be tested for leaks after the installation is completed. After ensuring that the manual shutoff gas valve is open, apply a soap and water solution to all connections and joints. If bubbles appear, leaks can be detected and corrected. **DO NOT USE OPEN FLAME FOR LEAK TESTING AND DO NOT OPERATE ANY APPLIANCE IF A LEAK IS DETECTED.**

GAS SUPPLY TESTING

Note: This section is intended as a guide for qualified technicians installing gas to this vent-free firebox.

CAUTION: Do not connect vent-free appliance before pressure testing gas piping. Damage to gas valve may result and an unsafe condition may be caused.

The appliance and its' individual shutoff valve must be disconnected from the gas supply piping system during any pressure testing of that system at test pressures in excess of 1/2 psig (3.5 kPa).

The appliance must be isolated from the gas supply piping system by closing manual shutoff valve during any pressure testing of the gas supply piping system at test pressures equal to or less than 1/2 psig (3.5 kPa).

HARD-WIRING FIREBOX

This model can be hard-wired to the duplex outlet located inside the firebox bottom if desired. This allows the blower accessory to be plugged into the duplex outlet.

NOTICE: A qualified electrician must connect electrical wiring to duplex outlet for built-in installation. Follow all local codes. In absence of local codes follow The National Electric Code ANSI/NFPA 70.

ELECTRICAL INSTALLATION

A model GA3500A blower system assembly is available for use with the vent-free firebox as an optional accessory. This blower is designed to be installed on either side of the firebox, when provisions for a 120 VAC supply connection are made at either end of the cabinet. Use of a blower system other than those manufactured by INNOVATIVE HEARTH PRODUCTS voids the warranty.

Electrical connections are made within the receptacle with wires that are routed through the bushing provided (see Figure 15). The receptacle may be relocated to either side, when necessary. However, the cover plate must be replaced over the unused access point. Be certain to properly ground the vent-free firebox using the green grounding wire.

Note: A 120V supply connection to the leads

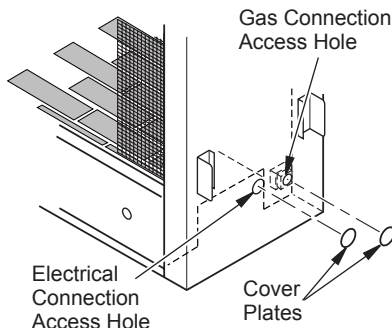

Figure 15 - Locating Electrical Connection and Gas Connection on Either Side of Fireplace

INSTALLATION

Continued

to the receptacle must be provided for use with the optional blower kit whether installed during or after initial firebox installation. You may not be able to install a supply connection after the final installation is completed.

CAUTION: Do not clean hood with abrasive cleanser. Use only regular household cleaners and a smooth cloth.

HEAT DEFLECTIVE HOOD INSTALLATION

The factory supplied heat deflective hoods must be installed inside the fireplace opening on both sides for the safe operation of the unit as shown in Figure 16.

1. Remove protective covering from hoods.
2. Position deflective hood into opening on one side of the firebox and secure to the top of the opening using screws provided.
3. Secure the ends of the hood to the firebox using two screws (provided) for each side.
4. Repeat steps 2 and 3 to install hood on the remaining side and end of the firebox.

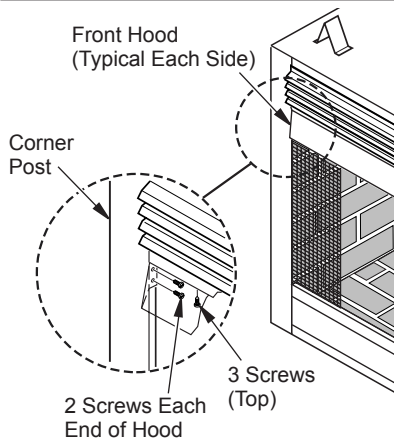

Figure 16 - Typical Hood Installation (Both Sides)

OPERATING GUIDELINES AND MAINTENANCE INSTRUCTIONS

When lit for the first time, a vent-free log appliance will emit a slight odor for about an hour or two. This is a normal occurrence which is due to the “curing” of the logs and the “burn-in” of internal paints and lubricants used in the manufacturing process.

Keep control compartments, logs, burners and areas surrounding the logs clean by vacuuming or brushing at least twice a year. Temporary removal of the log set may ease the cleaning of the burner and pilot assembly. In cleaning, take care not to alter the settings on the pilot assembly. See the operating instructions supplied with your vent-free log appliance for additional cleaning instructions.

WARNING: Logs can be very hot! Allow logs to cool before handling.

Installation and repair should be done by a qualified person. The appliance should be inspected before use and at least annually by a professional service person. More frequent cleaning may be required due to excessive lint from carpeting, pet hair, etc. It is imperative that the control compartments, burners and circulating air passageways of the appliance be kept clean.

WARNING: Children and adults should be alerted to the hazards of high surface temperatures and to stay away to avoid burns or clothing ignition. Young children should be carefully supervised when they are in the same room as the appliance.

IMPORTANT: Turn off the gas supply at the external shutoff valve before servicing appliance. Any safety screen or guard removed for servicing must be replaced prior to operating the appliance.

For lighting and operating this vent-free firebox, please refer to the vent-free gas logs manufacturer's instruction manual.

REPLACEMENT PARTS

Note: Use only original replacement parts. This will protect your warranty coverage for parts replaced under warranty.

Contact authorized dealers of this product. If they can't supply original replacement part(s), call INNOVATIVE HEARTH PRODUCTS at 1-800-655-2008.

When calling, have ready:

- your name
- your address
- model and serial numbers of your appliance
- how appliance was malfunctioning
- purchase date

Usually, we will ask you to return the part to the factory.

TECHNICAL SERVICE

You may have further questions about installation, operation, or troubleshooting. If so, contact INNOVATIVE HEARTH PRODUCTS at 1-800-655-2008. When calling please have your model and serial numbers of your appliance ready.

You can also visit the INNOVATIVE HEARTH PRODUCTS web site at **www.IHP.US.com**.

ACCESSORY

Purchase these accessories from your local dealer. If they can not supply these accessories call INNOVATIVE HEARTH PRODUCTS at 1-800-655-2008 for information. You can also write to the address listed on the back page of this manual.

PARTS

MODEL TAURUSPFZ2

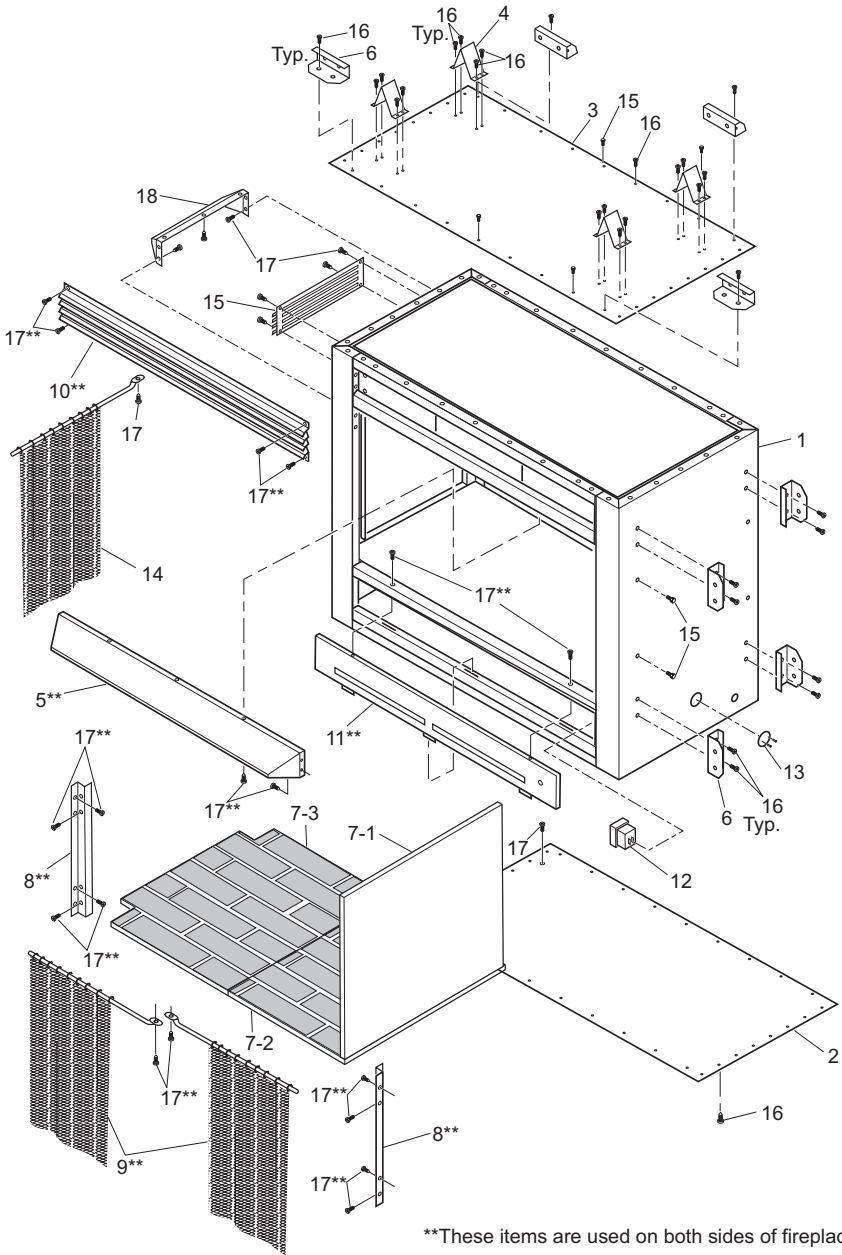

**These items are used on both sides of fireplace.

PARTS

MODEL TAURUSPFZ2

This list contains replaceable parts used in your firebox. When ordering parts, follow the instructions listed under Replacement Parts on page 15 of this manual.

KEY NO.	PART NO.	DESCRIPTION	QTY.
1	***	Firebox Assembly	1
2	***	Firebox Bottom	1
3	***	Firebox Top	1
4	23982	Top Spacer	4
5	26731	Deflector Hood	2
6	26740	Nailing Flange	12
7-1	02013	Side Refractory Brick Liner	1
7-2	02014	Bottom Refractory Brick Liner	1
7-3	02036	Bottom Refractory Brick Liner	1
8	24007	Side Refractory Retainer	2
9	12125	Screen	4
10	26752	Extruded Louver	2
11	26733	Lower Door Panel	2
12	14200	Receptacle	1
13	21171	Access Hole Cover	3
14	12126	Screen	1
15	26771	Extruded Louver (End)	1
16	11164	Screw, #10 x 1/2, zinc PH	24
17	11165	Screw, #10 x 5/8, zinc PH	67
18	26762	Deflector Hood (End)	1

*** Not a field replaceable part.

Innovative Hearth Products Astria™ Brand Gas Fireplace Limited Lifetime Warranty

THE WARRANTY

Innovative Hearth Products ("IHP") Limited Lifetime Warranty warrants your Astria™ brand gas fireplace ("Product") to be free from defects in materials and workmanship at the time of manufacture. The Product body and firebox carry the Limited Lifetime Warranty. Ceramic glass carries the Limited Lifetime Warranty against thermal breakage only. After installation, if covered components manufactured by IHP are found to be defective in materials or workmanship during the Limited Lifetime Warranty period and while the Product remains at the site of the original installation, IHP will, at its option, repair or replace the covered components. If repair or replacement is not commercially practical, IHP will, at its option, refund the purchase price or wholesale price of the IHP product, whichever is applicable. IHP will also pay IHP prevailing labor rates, as determined in its sole discretion, incurred in repairing or replacing such components for up to five years. THERE ARE EXCLUSIONS AND LIMITATIONS to this Limited Lifetime Warranty as described herein.

COVERAGE COMMENCEMENT DATE

Warranty coverage begins on the date of installation. In the case of new home construction, warranty coverage begins on the date of first occupancy of the dwelling or six months after the sale of the Product by an independent IHP dealer/distributor, whichever occurs earlier. The warranty shall commence no later than 24 months following the date of product shipment from IHP, regardless of the installation or occupancy date.

EXCLUSIONS AND LIMITATIONS

This Limited Lifetime Warranty applies only if the Product is installed in the United States or Canada and only if operated and maintained in accordance with the printed instructions accompanying the Product and in compliance with all applicable installation and building codes and good trade practices.

This warranty is non-transferable and extends to the original owner only. The Product must be purchased through a listed supplier of IHP and proof of purchase must be provided. The Product body and firebox carry the Limited Lifetime Warranty from the date of installation. Vent components, trim components and paint are excluded from this Limited Lifetime Warranty. The following do not carry the Limited Lifetime Warranty but are warranted as follows:

Burner – Repair or replacement for five years from the date of installation

Gas components & electrical components – Repair or replacement for one year from the date of installation

Gaskets – Repair or replacement for one year from the date of installation

Gold & nickel plating - Replacement for two years from date of installation. Excludes tarnishing

Labor coverage – Prevailing IHP labor rates apply for the warranty period of the component

Light bulbs & batteries – Replacement for 90 days from the date of installation

Logs – Replacement for five years from the date of installation against thermal breakage only

Optional blowers & remote controls – Repair or replacement for one year from the date of installation

Optional glass doors & optional glass accessories – Repair or replacement for 90 days from the date of installation

Optional surrounds – Stone/Natural Materials: Replacement for one year against cracking or breakage due to thermal stress. Other Materials: Replacement for one year. Excludes surface and hairline cracks and scratches or slight color changes that do not affect the operation or safety of the unit

Tempered Glass -Replacement for one year from the date of installation

Parts not otherwise listed carry a 90 day warranty from the date of installation.

Whenever practicable, IHP will provide replacement parts, if available, for a period of 10 years from the last date of manufacture of the Product.

IHP will not be responsible for: (a) damages caused by normal wear and tear, accident, riot, fire, flood or acts of God; (b) damages caused by abuse, negligence, misuse, or unauthorized alteration or repair of the Product affecting its stability or performance (The Product must be subjected to normal use. The Product is designed to burn either natural or propane gas only. Burning conventional fuels such as wood, coal or any other solid fuel will cause damage to the Product, will produce excessive temperatures and could result in a fire hazard.); (c) damages caused by failing to provide proper maintenance and service in accordance with the instructions provided with the Product; (d) damages, repairs or inefficiency resulting from faulty installation or application of the Product.

IHP is not responsible for inadequate fireplace system draft caused by air conditioning and heating systems, mechanical ventilation systems, or general construction conditions which may generate negative pressure in the room in which the appliance is installed. Additionally IHP assumes no responsibility for drafting conditions caused by venting configurations, adjoining trees or buildings, adverse wind conditions or unusual environmental factors and conditions that affect the operation of the unit.

This Limited Lifetime Warranty covers only parts and labor as provided herein. In no case shall IHP be responsible for materials, components or construction, which are not manufactured or supplied by IHP or for the labor necessary to install, repair or remove such materials, components or construction. Additional utility bills incurred due to any malfunction or defect in equipment are not covered by this warranty. All replacement or repair components will be shipped F.O.B. from the nearest stocking IHP factory.

LIMITATION ON LIABILITY

It is expressly agreed and understood that IHP's sole obligation and the purchaser's exclusive remedy under this warranty, under any other warranty, expressed or implied, or in contract, tort or otherwise, shall be limited to replacement, repair, or refund, as specified herein.

In no event shall IHP be liable for any incidental or consequential damages caused by defects in the Product, whether such damage occurs or is discovered before or after repair or replacement, and whether such damage is caused by IHP's negligence. IHP has not made and does not make any representation or warranty of fitness for a particular use or purpose, and there is no implied condition of fitness for a particular use or purpose.

IHP makes no expressed warranties except as stated in this Limited Lifetime Warranty. The duration of any implied warranty is limited to the duration of this expressed warranty.

No one is authorized to change this Limited Lifetime Warranty or to create for IHP any other obligation or liability in connection with the Product. Some states and provinces do not allow the exclusion or limitation of incidental or consequential damages, so the above limitations or exclusions may not apply to you. The provisions of this Limited Lifetime Warranty are in addition to and not a modification of or subtraction from any statutory warranties and other rights and remedies provided by law.

INVESTIGATION OF CLAIMS AGAINST WARRANTY

IHP reserves the right to investigate any and all claims against this Limited Lifetime Warranty and to decide, in its sole discretion, upon the method of settlement.

To receive the benefits and advantages described in this Limited Lifetime Warranty, the appliance must be installed and repaired by a licensed contractor approved by IHP.

Contact IHP at the address provided herein to obtain a listing of approved dealers/distributors. **IHP shall in no event be responsible for any warranty work done by a contractor that is not approved without first obtaining IHP's prior written consent.**

HOW TO REGISTER A CLAIM AGAINST WARRANTY

In order for any claim under this warranty to be valid, you must contact the IHP dealer/distributor from which you purchased the product. If you cannot locate the dealer/distributor, then you must notify IHP in writing. IHP must be notified of the claimed defect in writing within 90 days of the date of failure. Notices should be directed to the IHP Warranty Department at 1508 Elm Hill Pike, Suite 108, Nashville, TN 37210 or visit our website at WWW.ASTRIA.US.COM.

WARRANTY

KEEP THIS WARRANTY

Model (located on product or identification tag) _____

Serial No. (located on product or identification tag) _____

Date Purchased _____

Keep receipt for warranty verification.



P126688-01



1508 Elm Hill Pike, Suite 108
Nashville, TN 37210
1-800-655-2008
www.IHP.US.com

126688-01
Rev. A
02/14