

# Installation Manual

## Installation and Appliance Setup

**INSTALLER:** Leave this manual with party responsible for use and operation.  
**OWNER:** Retain this manual for future reference.

**NOTICE:** DO NOT discard this manual!

**HEAT & GLO**

No one builds a better fire

**Models:**

**LUX36**

**LUX42**

**GAS-FIRED**

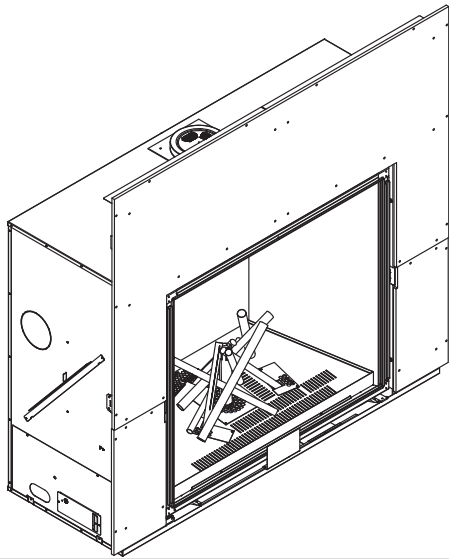

This appliance may be installed as an OEM installation in manufactured home (USA only) or mobile home and must be installed in accordance with the manufacturer's instructions and the *Manufactured Home Construction and Safety Standard, Title 24 CFR, Part 3280* in the United States, or the *Standard for Installation in Mobile Homes, CAN/CSA Z240 MH Series*, in Canada.

This appliance is only for use with the type(s) of gas indicated on the rating plate. This appliance is not convertible for use with other gases, unless a certified kit is used.

In the Commonwealth of Massachusetts installation must be performed by a licensed plumber or gas fitter.  
See Table of Contents for location of additional Commonwealth of Massachusetts requirements.

**⚠ WARNING:** If the information in these instructions is not followed exactly, a fire or explosion may result causing property damage, personal injury, or death.

- **DO NOT** store or use gasoline or other flammable vapors and liquids in the vicinity of this or any other appliance.
- **What to do if you smell gas**
  - **DO NOT** try to light any appliance.
  - **DO NOT** touch any electrical switch. **DO NOT** use any phone in your building.
  - Immediately call your gas supplier from a neighbor's phone. Follow the gas supplier's instructions.
  - If you cannot reach your gas supplier, call the fire department.
- Installation and service must be performed by a qualified installer, service agency, or the gas supplier.

**⚠ WARNING**



**HOT GLASS WILL CAUSE BURNS.  
DO NOT TOUCH GLASS UNTIL COOLED.  
NEVER ALLOW CHILDREN TO TOUCH GLASS.**

A barrier designed to reduce the risk of burns from the hot viewing glass is provided with this appliance and shall be installed.

Pour demander un exemplaire en français de ce Manuel du propriétaire, visitez [www.heatnglo.com/translations](http://www.heatnglo.com/translations).

## ▲ Safety Alert Key:

- **DANGER!** Indicates a hazardous situation which, if not avoided will result in death or serious injury.
- **WARNING!** Indicates a hazardous situation which, if not avoided could result in death or serious injury.
- **CAUTION!** Indicates a hazardous situation which, if not avoided, could result in minor or moderate injury.
- **NOTICE:** Used to address practices not related to personal injury.

## Table of Contents

Installation Standard Work Checklist . . . . .	3	<b>7 Venting and Chimneys</b>	
<b>1 Product Specific and Important Safety Information</b>		A. Assemble Vent Sections . . . . .	30
A. Appliance Certification . . . . .	4	B. Secure the Vent Sections . . . . .	31
B. Glass Specifications . . . . .	4	C. Disassemble Vent Sections . . . . .	31
C. BTU Specifications . . . . .	4	D. Vertical Termination Requirements . . . . .	32
D. High Altitude Installations . . . . .	4	E. Horizontal Termination Requirements . . . . .	33
E. Non-Combustible Materials Specification . . . . .	4	<b>8 Electrical Information</b>	
F. Combustible Materials Specification . . . . .	4	A. General Information . . . . .	35
G. Electrical Codes . . . . .	4	B. Wiring Requirements . . . . .	37
H. Requirements for the Commonwealth of Massachusetts . . . . .	5	<b>9 Gas Information</b>	
<b>2 Getting Started</b>		A. Fuel Conversion . . . . .	38
A. Design and Installation Considerations . . . . .	6	B. Gas Pressure . . . . .	38
B. Tools and Supplies Needed . . . . .	6	C. Gas Connection . . . . .	38
C. Inspect Appliance and Components . . . . .	6	D. High Altitude Installations . . . . .	38
<b>3 Framing and Clearances</b>		E. Air Shutter Setting . . . . .	39
A. Appliance/Decorative Front Dimension Diagrams . . . . .	7	<b>10 Finishing</b>	
B. Clearances to Combustibles . . . . .	11	A. Finishing Templates . . . . .	40
C. Constructing the Appliance Chase . . . . .	12	B. Facing Material . . . . .	41
D. Hearth Extension . . . . .	13	C. Splatter Guard . . . . .	41
<b>4 Termination Location and Vent Information</b>		D. Mantel and Wall Projections . . . . .	42 ←
A. Vent Termination Minimum Clearances . . . . .	14	E. Doors . . . . .	43
B. Chimney Diagram . . . . .	15	<b>11 Appliance Setup</b>	
C. Approved Pipe . . . . .	16	A. Fixed Glass Assembly . . . . .	44 ←
D. Use of Elbows . . . . .	16	B. Remove the Shipping Materials . . . . .	46
→ E. Measuring Standards . . . . .	16	C. Clean the Appliance . . . . .	46
F. Vent Diagrams . . . . .	17	D. Glass Refractory Installation . . . . .	46
G. PVK-80 and PVI-SLP Information . . . . .	23	E. Media Placement . . . . .	47
<b>5 Vent Clearances and Framing</b>		F. Burner Tube Removal . . . . .	48
A. Pipe Clearances to Combustibles . . . . .	24	<b>12 Reference Materials</b>	
B. Wall Penetration Framing/Firestops . . . . .	24	A. Vent Components Diagrams . . . . .	49 ←
C. Ceiling Firestop/Floor Penetration Framing . . . . .	25	B. Accessories . . . . .	53
→ D. Install Attic Insulation Shield . . . . .	25		
E. Installing the Optional Heat-Zone® Gas Kit . . . . .	26		
<b>6 Appliance Preparation</b>			
A. Vent Collar Preparation . . . . .	27		
B. Securing and Leveling the Appliance . . . . .	28		
C. Non-Combustible Material Installation . . . . .	29		

→ = Contains updated information.

# Installation Standard Work Checklist

## ATTENTION INSTALLER: Follow this Standard Work Checklist

This standard work checklist is to be used by the installer in conjunction with, not instead of, the instructions contained in this installation manual.

<b>Customer:</b> _____	<b>Date Installed:</b> _____
<b>Lot/Address:</b> _____	<b>Location of Fireplace:</b> _____
	<b>Installer:</b> _____
<b>Model (circle one):</b> LUX36 _____	<b>Dealer/Distributor Phone #:</b> _____
LUX42 _____	<b>Serial #:</b> _____

**WARNING! Risk of Fire or Explosion!** Failure to install appliance according to these instructions can lead to a fire or explosion.

<u>Appliance Install Information</u>	YES	IF NO, WHY?
Verified clearances to combustibles requirements are maintained. (Pg. 11-12)	<input type="checkbox"/>	_____
Verified that the chase is insulated and sealed. (Pg. 12)	<input type="checkbox"/>	_____
Verified mantel and wall clearance requirements are maintained. (Pg. 42-43)	<input type="checkbox"/>	_____
Verified hearth extension requirements are maintained. (Pg. 13)	<input type="checkbox"/>	_____
Verified appliance is leveled and secured. (Pg. 28)	<input type="checkbox"/>	_____
Verified required factory-supplied non-combustible board installed. (Pg. 29)	<input type="checkbox"/>	_____
<b><u>Venting/Chimney Section 7 (Pg. 30-34)</u></b>		
Verified venting configuration complies to vent diagrams.	<input type="checkbox"/>	_____
Verified venting installed, locked and sealed/secured in place.	<input type="checkbox"/>	_____
Verified venting meets clearance to combustible requirements.	<input type="checkbox"/>	_____
Verified wall/ceiling firestops are installed (if applicable).	<input type="checkbox"/>	_____
Verified attic insulation shield is installed (if applicable).	<input type="checkbox"/>	_____
Verified Exterior wall/Roof flashing is installed and sealed.	<input type="checkbox"/>	_____
Verified termination cap is installed and sealed.	<input type="checkbox"/>	_____
<b><u>Electrical Section 8 (Pg. 35-37)</u></b>		
Verified unswitched power (110-120 VAC) provided to the appliance.	<input type="checkbox"/>	_____
Verified wall switch wires are properly installed (if applicable).	<input type="checkbox"/>	_____
<b><u>Gas Section 9 (Pg. 38-39)</u></b>		
Verified appliance is using proper fuel type.	<input type="checkbox"/>	_____
If converted, verified proper fuel conversion kit was used.	<input type="checkbox"/>	_____
Verified that gas components (fittings, pressure taps, etc) are leak free and fireplace is operating under correct pressures.	<input type="checkbox"/>	_____
<b><u>Finishing Section 10 (Pg. 40-43)</u></b>		
Verified that finish material does not interfere with install/operation of decorative front.	<input type="checkbox"/>	_____
Verified combustible materials are not installed in non-combustible areas.	<input type="checkbox"/>	_____
Verified all clearances meet installation manual requirements.	<input type="checkbox"/>	_____
Verified mantels/wall projections comply with installation manual requirements.	<input type="checkbox"/>	_____
<b><u>Appliance Setup Section 11 (Pg. 44-48)</u></b>		
Verified all packaging and protective materials are removed (inside & outside of appliance).	<input type="checkbox"/>	_____
Verified black glass panels are installed correctly.	<input type="checkbox"/>	_____
Verified media installed correctly.	<input type="checkbox"/>	_____
Verified fixed glass assembly installed and secured.	<input type="checkbox"/>	_____
Verified that a required decorative door option is installed properly.	<input type="checkbox"/>	_____
Verified remote control has been programmed and is fully functional.	<input type="checkbox"/>	_____
Verified air shutters set properly for installation type and vent configuration.	<input type="checkbox"/>	_____
Manual bag and all of its contents are removed from inside/under the appliance and given to party responsible for use and operation.	<input type="checkbox"/>	_____

**Hearth & Home Technologies recommends the following:**

- Photographing the installation and copying this checklist for your file.
- That this checklist remain visible at all times on the appliance until the installation is complete.

**Comments:** Further description of the issues, who is responsible (Installer/ Builder/ Other Trades, etc) and corrective action needed \_\_\_\_\_

Comments Communicated to party responsible \_\_\_\_\_ by \_\_\_\_\_ on \_\_\_\_\_  
 (Builder / Gen. Contractor/) (Installer) (Date)

➔ = Contains updated information.

# 1 Product Specific and Important Safety Information

## A. Appliance Certification

**MODELS:** LUX36, LUX42  
**LABORATORY:** Underwriters Laboratories, Inc. (UL)  
**TYPE:** Direct Vent Heater  
**STANDARD:** ANSI Z21.88-2009 • CSA 2.33-2009

This product is listed to ANSI standards for “Vented Gas Fireplace Heaters” and applicable sections of “Gas Burning Heating Appliances for Manufactured Homes and Recreational Vehicles”, and “Gas Fired Appliances for Use at High Altitudes”.

**NOTICE:** This installation must conform with local codes. In the absence of local codes you must comply with the National Fuel Gas Code, ANSI Z223.1-latest edition in the U.S.A. and the CAN/CGA B149 Installation Codes in Canada.

**NOT INTENDED FOR USE AS A PRIMARY HEAT SOURCE.**  
 This appliance is tested and approved as either supplemental room heat or as a decorative appliance. It should not be factored as primary heat in residential heating calculations.

## B. Glass Specifications

This appliance is equipped with 5 mm ceramic glass. Replace glass only with 5 mm ceramic glass. Please contact your dealer for replacement glass.

## C. BTU Specifications

Models (U.S. or Canada)		Maximum Input BTU/h	Orifice Size (DMS)			
			Left	Right	Rear	Center
LUX36 (NG)	US (0-2000 FT)	38,000	#51	#51	#51	#60
	CANADA (2000-4500 FT)	34,000	#52	#52	#52	#61
LUX42 (NG)	US (0-2000 FT)	49,000	#47	#47	#48	#58
	CANADA (2000-4500 FT)	44,000	#48	#48	#49	#59

## D. High Altitude Installations

**NOTICE:** If the heating value of the gas has been reduced, these rules do not apply. Check with your local gas utility or authorities having jurisdiction.

When installing above 2000 feet elevation:

- In the USA: Reduce input rate 4% for each 1000 feet above 2000 feet.
- In CANADA: Reduce input rate 10% for elevations between 2000 feet and 4500 feet. Above 4500 feet, consult local gas utility.

Check with your local gas utility to determine proper orifice size.

## E. Non-Combustible Materials Specification

Material which will not ignite and burn. Such materials are those consisting entirely of steel, iron, brick, tile, concrete, slate, glass or plasters, or any combination thereof.

Materials that are reported as passing **ASTM E 136, Standard Test Method for Behavior of Materials in a Vertical Tube Furnace at 750 °C** shall be considered non-combustible materials.

## F. Combustible Materials Specification

Materials made of or surfaced with wood, compressed paper, plant fibers, plastics, or other material that can ignite and burn, whether flame proofed or not, or plastered or unplastered shall be considered combustible materials.

## G. Electrical Codes

**NOTICE:** This appliance must be electrically wired and grounded in accordance with local codes or, in the absence of local codes, with **National Electric Code ANSI/NFPA 70-latest edition or the Canadian Electric Code CSA C22.1.**

- A 110-120 VAC circuit for this product must be protected with ground-fault circuit-interrupter protection, in compliance with the applicable electrical codes, when it is installed in locations such as in bathrooms or near sinks.

**Note:** The following requirements reference various Massachusetts and national codes not contained in this document.

## H. Requirements for the Commonwealth of Massachusetts

For all side wall horizontally vented gas fueled equipment installed in every dwelling, building or structure used in whole or in part for residential purposes, including those owned or operated by the Commonwealth and where the side wall exhaust vent termination is less than seven (7) feet above finished grade in the area of the venting, including but not limited to decks and porches, the following requirements shall be satisfied:

### Installation of Carbon Monoxide Detectors

At the time of installation of the side wall horizontal vented gas fueled equipment, the installing plumber or gas fitter shall observe that a hard wired carbon monoxide detector with an alarm and battery back-up is installed on the floor level where the gas equipment is to be installed. In addition, the installing plumber or gas fitter shall observe that a battery operated or hard wired carbon monoxide detector with an alarm is installed on each additional level of the dwelling, building or structure served by the side wall horizontal vented gas fueled equipment. It shall be the responsibility of the property owner to secure the services of qualified licensed professionals for the installation of hard wired carbon monoxide detectors.

In the event that the side wall horizontally vented gas fueled equipment is installed in a crawl space or an attic, the hard wired carbon monoxide detector with alarm and battery back-up may be installed on the next adjacent floor level.

In the event that the requirements of this subdivision can not be met at the time of completion of installation, the owner shall have a period of thirty (30) days to comply with the above requirements; provided, however, that during said thirty (30) day period, a battery operated carbon monoxide detector with an alarm shall be installed.

### Approved Carbon Monoxide Detectors

Each carbon monoxide detector as required in accordance with the above provisions shall comply with NFPA 720 and be ANSI/UL 2034 listed and IAS certified.

### Signage

A metal or plastic identification plate shall be permanently mounted to the exterior of the building at a minimum height of eight (8) feet above grade directly in line with the exhaust vent terminal for the horizontally vented gas fueled heating appliance or equipment. The sign shall read, in print size no less than one-half (1/2) in. in size, "**GAS VENT DIRECTLY BELOW. KEEP CLEAR OF ALL OBSTRUCTIONS**".

## Inspection

The state or local gas inspector of the side wall horizontally vented gas fueled equipment shall not approve the installation unless, upon inspection, the inspector observes carbon monoxide detectors and signage installed in accordance with the provisions of 248 CMR 5.08(2)(a)1 through 4.

## Exemptions

The following equipment is exempt from 248 CMR 5.08(2)(a)1 through 4:

- The equipment listed in Chapter 10 entitled "Equipment Not Required To Be Vented" in the most current edition of NFPA 54 as adopted by the Board; and
- Product Approved side wall horizontally vented gas fueled equipment installed in a room or structure separate from the dwelling, building or structure used in whole or in part for residential purposes.

## MANUFACTURER REQUIREMENTS

### Gas Equipment Venting System Provided

When the manufacturer of Product Approved side wall horizontally vented gas equipment provides a venting system design or venting system components with the equipment, the instructions provided by the manufacturer for installation of the equipment and the venting system shall include:

- Detailed instructions for the installation of the venting system design or the venting system components; and
- A complete parts list for the venting system design or venting system.

### Gas Equipment Venting System NOT Provided

When the manufacturer of a Product Approved side wall horizontally vented gas fueled equipment does not provide the parts for venting the flue gases, but identifies "special venting systems", the following requirements shall be satisfied by the manufacturer:

- The referenced "special venting system" instructions shall be included with the appliance or equipment installation instructions; and
- The "special venting systems" shall be Product Approved by the Board, and the instructions for that system shall include a parts list and detailed installation instructions.

A copy of all installation instructions for all Product Approved side wall horizontally vented gas fueled equipment, all venting instructions, all parts lists for venting instructions, and/or all venting design instructions shall remain with the appliance or equipment at the completion of the installation.

**See Gas Connection section for additional Commonwealth of Massachusetts requirements.**

# 2 Getting Started

## A. Design and Installation Considerations

Heat & Glo direct vent gas appliances are designed to operate with all combustion air siphoned from outside of the building and all exhaust gases expelled to the outside. No additional outside air source is required.

Installation MUST comply with local, regional, state and national codes and regulations. Consult insurance carrier, local building inspector, fire officials or authorities having jurisdiction over restrictions, installation inspection and permits.

Before installing, determine the following:

- Where the appliance is to be installed.
- The vent system configuration to be used.
- Gas supply piping requirements.
- Electrical wiring requirements.
- Framing and finishing details.
- Whether optional accessories—devices such as a fan, wall switch, or remote control—are desired.



Installation and service of this appliance should be performed by qualified personnel. Hearth & Home Technologies suggests NFI certified or factory trained professionals, or technicians supervised by an NFI certified professional ([www.nficertified.org](http://www.nficertified.org)).

Improper installation, adjustment, alteration, service or maintenance can cause injury or property damage. For assistance or additional information, consult a qualified service technician, service agency or your dealer.

## B. Tools and Supplies Needed

Before beginning the installation be sure that the following tools and building supplies are available.

- |  |                                   |
|--|-----------------------------------|
| Tape measure   | Framing material                  |
| Pliers   | Hammer                            |
| Phillips screwdriver   | Manometer                         |
| Gloves   | Framing square                    |
| Voltmeter  | Electric drill and bits (1/4 in.) |
| Plumb line   | Safety glasses                    |
| Level  | Reciprocating saw                 |
| Flat blade screwdriver                                       |                                   |
| Non-corrosive leak check solution                            |                                   |
| 1/2 - 3/4 in. length, #6 or #8 Self-drilling screws          |                                   |
| Caulking material (300°F minimum continuous exposure rating) |                                   |

## C. Inspect Appliance and Components

- Carefully remove the appliance and components from the packaging.
- The vent system components and decorative doors and fronts may be shipped in separate packages.
- If packaged separately, the log set and appliance grate must be installed.
- Report to your dealer any parts damaged in shipment, particularly the condition of the glass.
- **Read all of the instructions before starting the installation. Follow these instructions carefully during the installation to ensure maximum safety and benefit.**

**WARNING! Risk of Fire or Explosion! Damaged parts could impair safe operation. DO NOT install damaged, incomplete or substitute components. Keep appliance dry.**

Hearth & Home Technologies disclaims any responsibility for, and the warranty will be voided by, the following actions:

- Installation and use of any damaged appliance or vent system component.
- Modification of the appliance or vent system.
- Installation other than as instructed by Hearth & Home Technologies.
- Improper positioning of the gas logs or the glass door.
- Installation and/or use of any component part not approved by Hearth & Home Technologies.

**Any such action may cause a fire hazard.**

**WARNING! Risk of Fire, Explosion or Electric Shock! DO NOT use this appliance if any part has been under water. Call a qualified service technician to inspect the appliance and to replace any part of the control system and/or gas control which has been under water.**

# 3 Framing and Clearances

## A. Appliance/Decorative Front Dimension Diagrams

Dimensions are actual appliance dimensions. Use for reference only. For framing dimensions and clearances refer to Section 5.

### APPLIANCE DIMENSION DIAGRAM (LUX36)

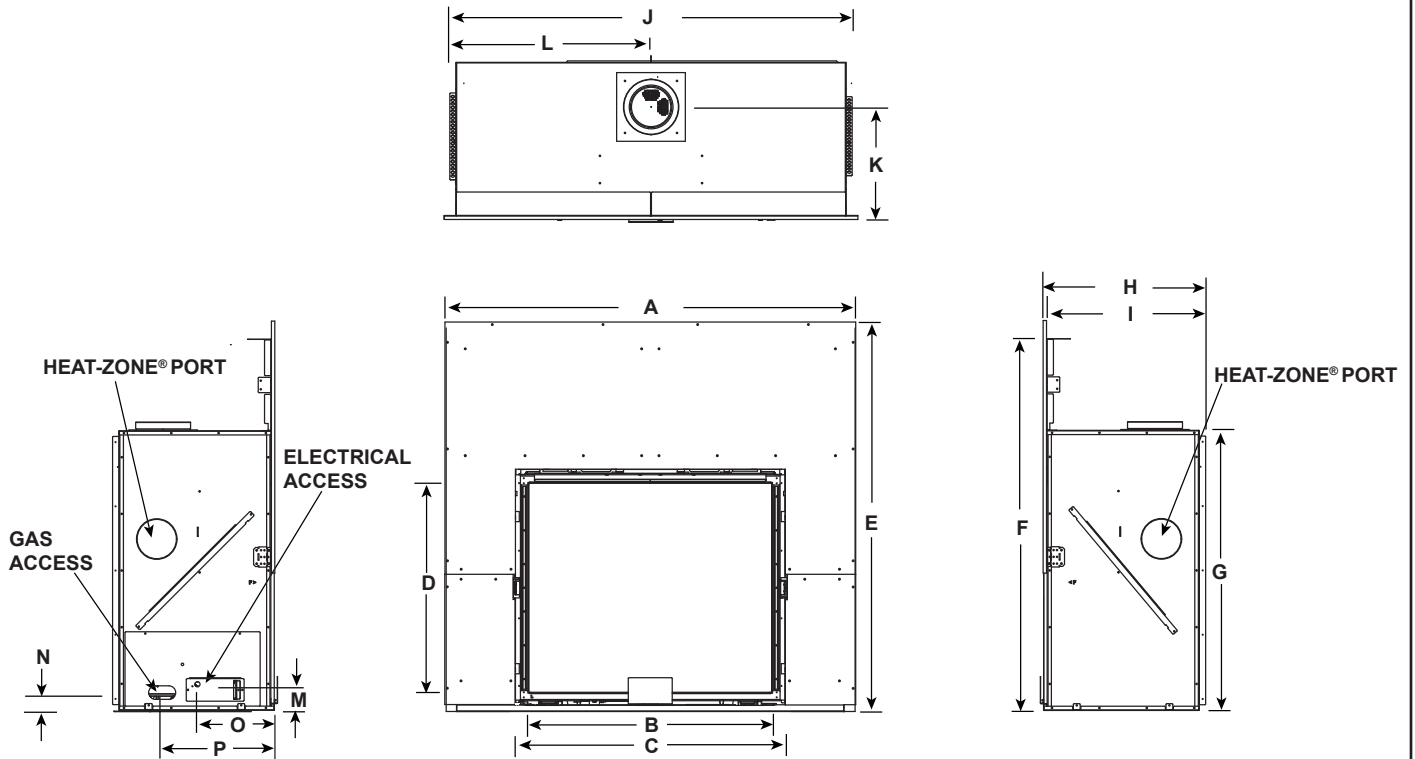

Appliance Dimensions Table LUX36

Location	Inches	Millimeters
A	61	1549
B	35-7/8	911
C	39-7/8	1013
D	31-1/16	789
E	57-5/8	1464
F	54-15/16	1395
G	41-3/8	1051
H	24	610

Location	Inches	Millimeters
I	23-1/2	597
J	59-1/4	1505
K	16	406
L	29-5/8	752
M	3-7/8	98
N	2-3/4	70
O	10-7/8	276
P	16-1/8	410

Figure 3.1 Appliance Dimensions (LUX36)

# APPLIANCE DIMENSION DIAGRAM (LUX42)

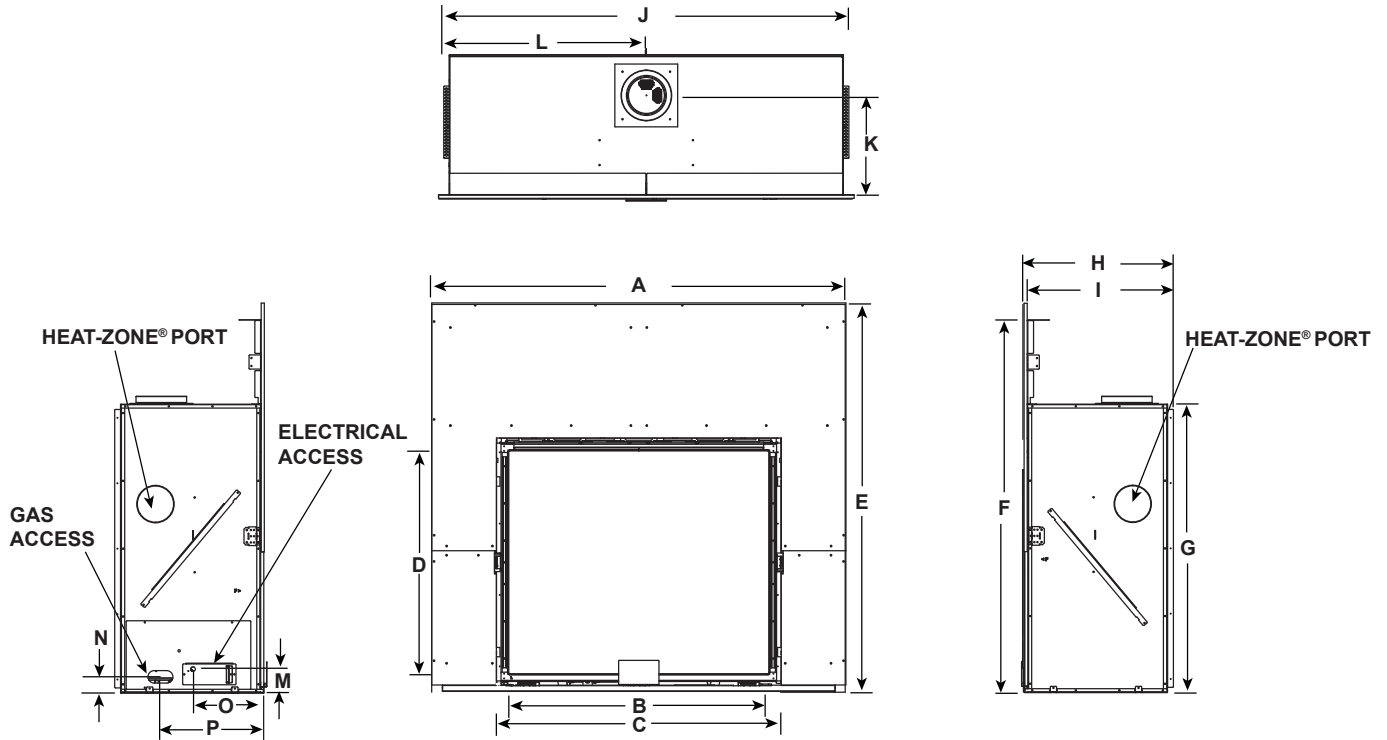

Appliance Dimensions Table LUX42

Location	Inches	Millimeters
A	67	1702
B	41-7/8	1064
C	45-7/8	1165
D	36-1/16	916
E	62-5/8	1591
F	59-15/16	1522
G	46-3/8	1178
H	24	610

Location	Inches	Millimeters
I	23-1/2	597
J	65-5/16	1659
K	16	406
L	32-11/16	830
M	3-7/8	98
N	2-3/4	70
O	10-7/8	276
P	16-1/8	410

Figure 3.2 Appliance Dimensions (LUX42)



# DECORATIVE FRONT DIMENSION DIAGRAM (LUX36)

See Section 10 for facing and finishing detail.

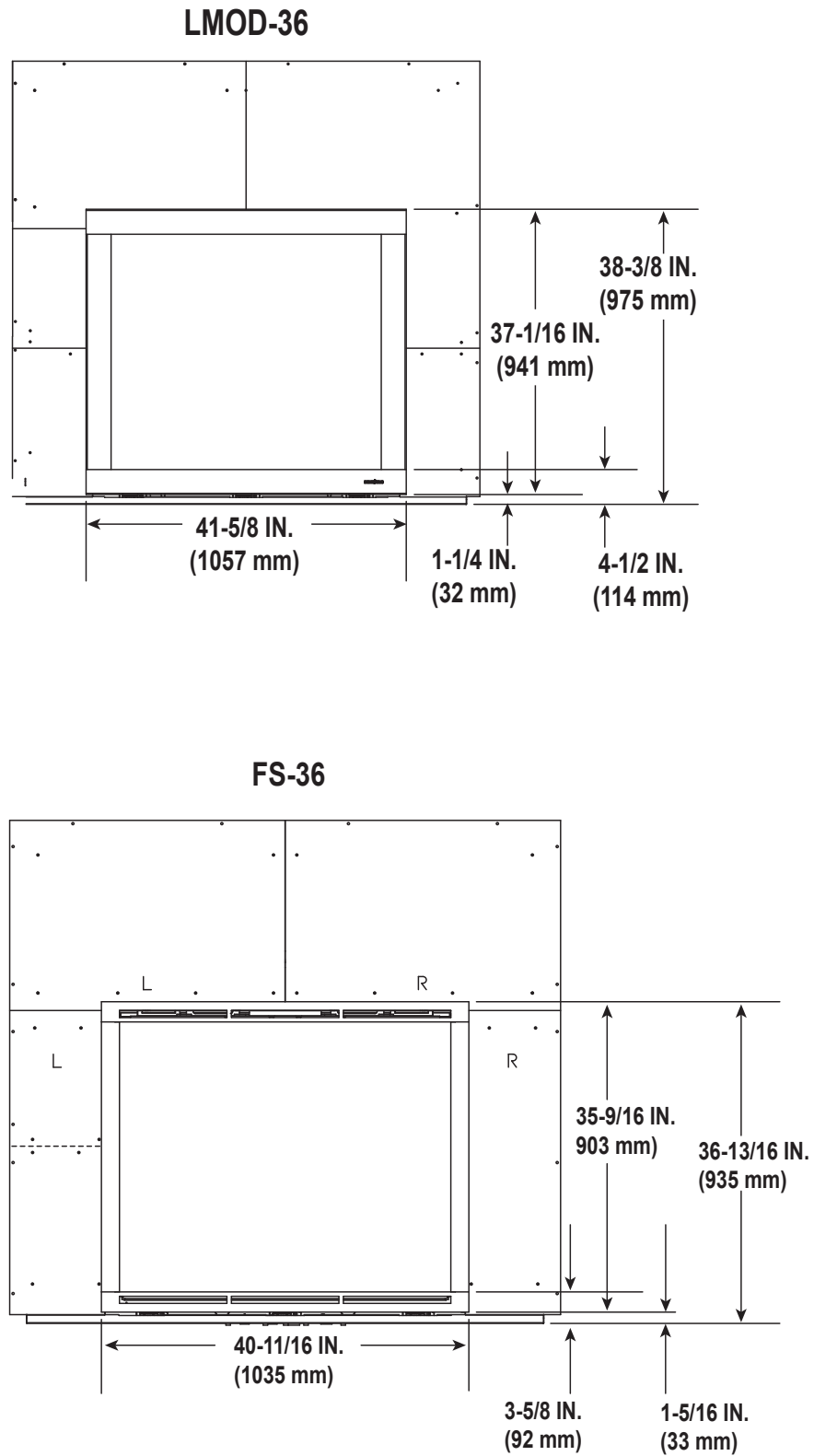
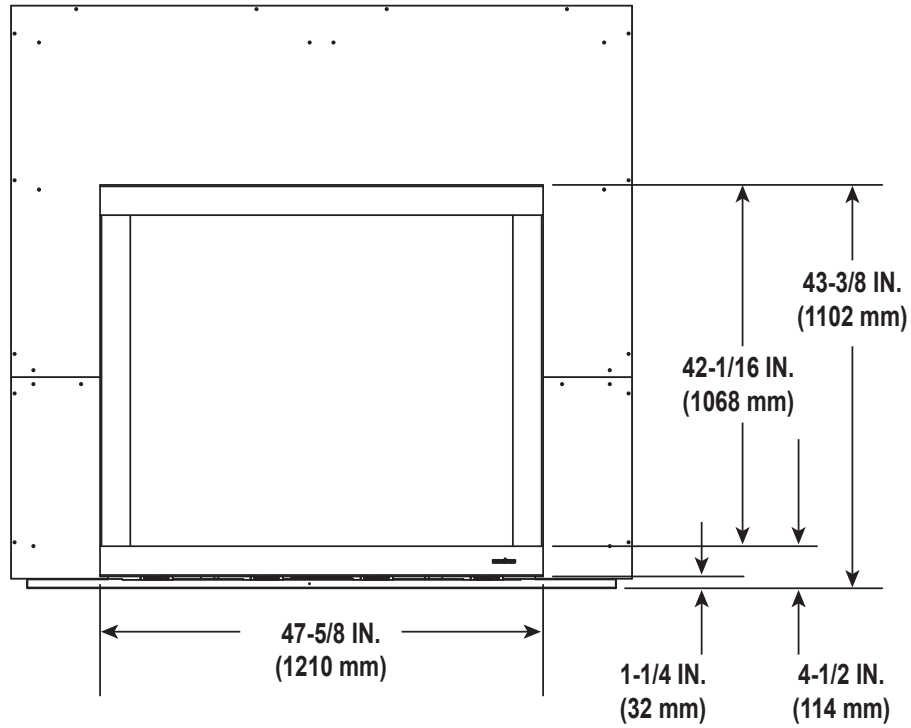

Figure 3.3 Decorative Front Dimensions (LUX36)

# DECORATIVE FRONT DIMENSION DIAGRAM (LUX42)

See Section 10 for facing and finishing detail.

## LMOD-42



## FS-42

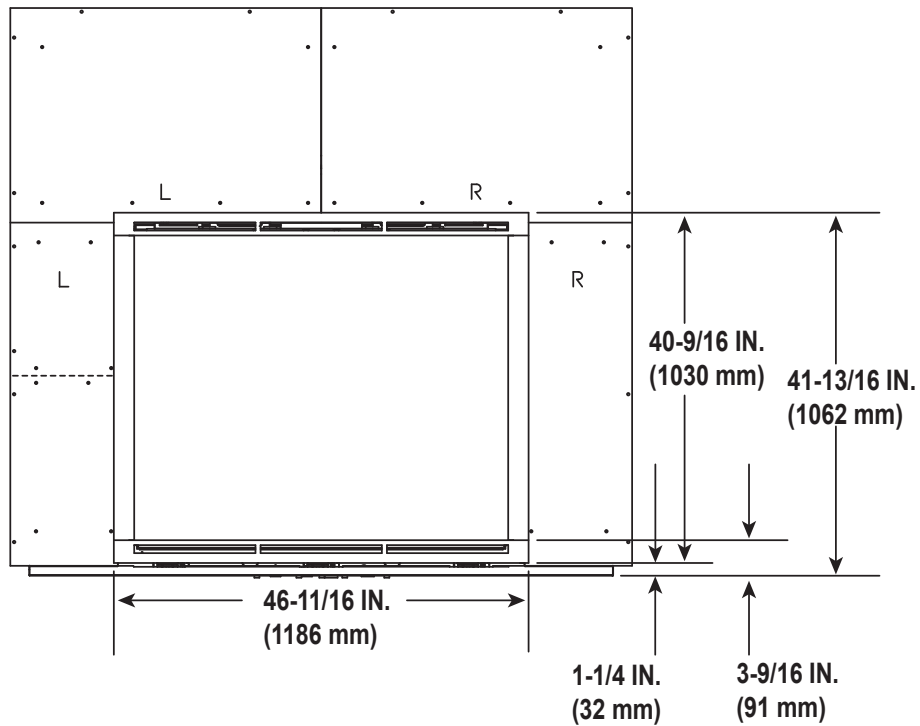

Figure 3.4 Decorative Front Dimensions (LUX42)

## B. Clearances to Combustibles

When selecting a location for the appliance it is important to consider the required clearances to walls (see Figure 3.5).

**WARNING! Risk of Fire or Burns!** Provide adequate clearance around air openings and for service access. Due to high temperatures, the appliance should be located out of traffic and away from furniture and draperies.

**NOTICE:** Illustrations reflect typical installations and are FOR DESIGN PURPOSES ONLY. Illustrations/diagrams are not drawn to scale. Actual installation may vary due to individual design preference.

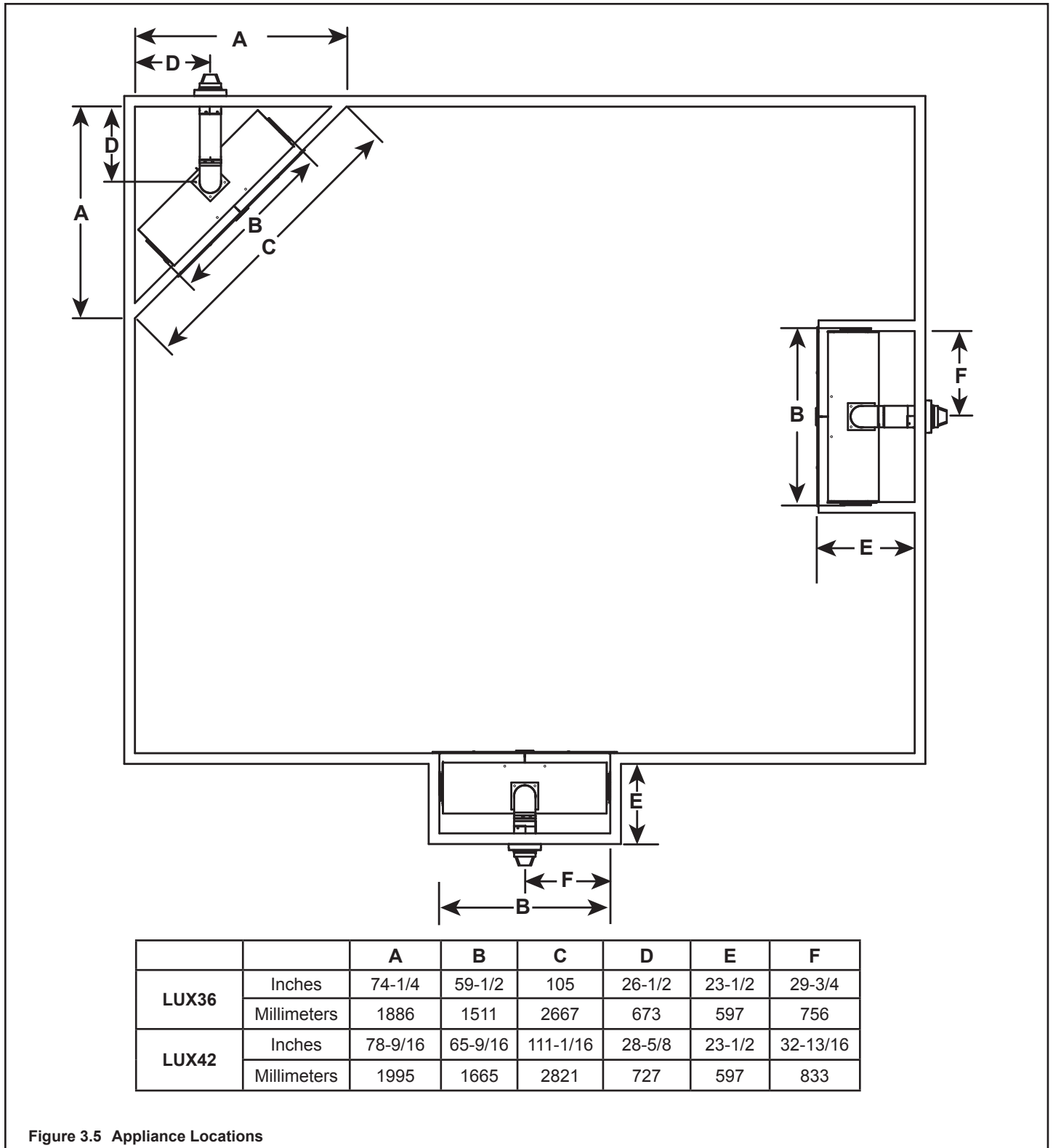

Figure 3.5 Appliance Locations

### C. Constructing the Appliance Chase

A chase is a vertical box-like structure built to enclose the gas appliance and/or its vent system. In cooler climates the vent should be enclosed inside the chase.

**NOTICE:** Treatment of ceiling firestops and wall shield firestops and construction of the chase may vary with the type of building. These instructions are not substitutes for the requirements of local building codes. Therefore, you **MUST** check local building codes to determine the requirements to these steps.

Chases should be constructed in the manner of all outside walls of the home to prevent cold air drafting problems. The chase should not break the outside building envelope in any manner.

Walls, ceiling, base plate and cantilever floor of the chase should be insulated. Vapor and air infiltration barriers should be installed in the chase as per regional codes for the rest of the home. Additionally, in regions where cold air infiltration may be an issue, the inside surfaces may be sheetrocked and taped for maximum air tightness.

To further prevent drafts, the wall shield and ceiling firestops should be caulked with caulk with a minimum of

300°F continuous exposure rating to seal gaps. Gas line holes and other openings should be caulked with caulk with a minimum of 300°F continuous exposure rating or stuffed with unfaced insulation. If the appliance is being installed on a cement surface, a layer of plywood may be placed underneath to prevent conducting cold up into the room.

**NOTICE:** Install appliance on hard metal or wood surfaces extending full width and depth. **DO NOT** install directly on carpeting, vinyl, tile or any combustible material other than wood.

**WARNING! Risk of Fire!** Maintain specified air space clearances to appliance and vent pipe:

- Insulation and other materials must be secured to prevent accidental contact.
- The chase must be properly blocked to prevent blown insulation or other combustibles from entering and making contact with fireplace or chimney.
- Failure to maintain airspace may cause overheating and a fire.

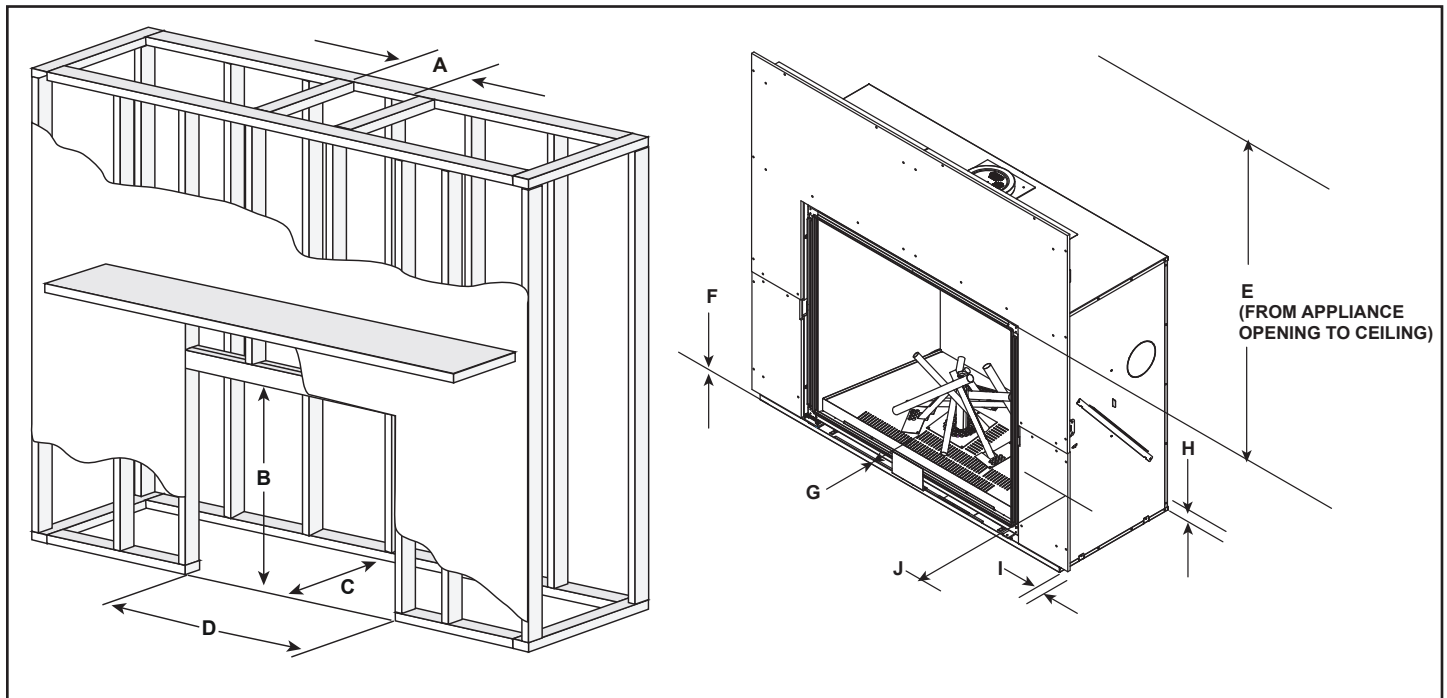

		* MINIMUM FRAMING DIMENSIONS									
		A	B	C	D	E	F	G	H	I	J
		Rough Opening (Vent Pipe)	Rough Opening (Height)	Rough Opening (Depth)	Rough Opening (Width)	Clearance to Ceiling	Combustible Floor	Hearth Extension	Behind Appliance	Sides of Appliance	Front of Appliance
LUX36	Inches	10	56	24	59-1/2	52	0	See Section 5.E.	1	1	36
	Millimeters	254	1422	610	1511	1321	0		25	25	914
LUX42	Inches	10	61	24	65-9/16	52	0		1	1	36
	Millimeters	254	1549	610	1665	1321	0		25	25	914

\* Adjust framing dimensions for interior sheathing (such as sheetrock)

Figure 3.6 Clearances to Combustibles

## D. Hearth Extension

**WARNING! Risk of Fire!** Non-combustible hearth extension may be required when appliance is installed on combustible surface.

- Hearth extension must be non-combustible and serves to protect combustible floors in front of appliance. See Figure 3.7 and Figure 3.8.
- The base of the fireplace may sit on a combustible surface. See Figure 3.8. The area in front of the appliance must be protected by a non-combustible hearth extension, unless the appliance is raised a minimum of three inches above the combustible floor or hearth. See Figure 3.8 and Figure 3.9.
- If a hearth greater than one inch in thickness is desired, the appliance must be raised by the equivalent height to ensure that the hearth extension does not interfere with the installation of the glass assembly. See Figure 3.8.

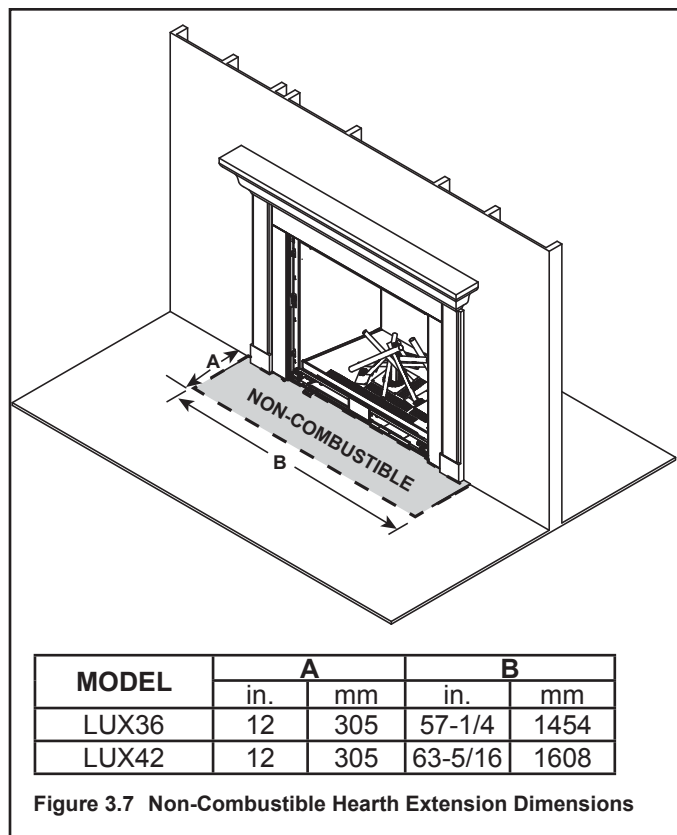

Figure 3.7 Non-Combustible Hearth Extension Dimensions

**NOTICE: DO NOT** install a hearth that is greater than one inch thick. Hearth will interfere with installation of glass assembly. Total hearth height must not exceed one inch from bottom of appliance when appliance is installed directly on floor (including mortar, backer material, etc.)

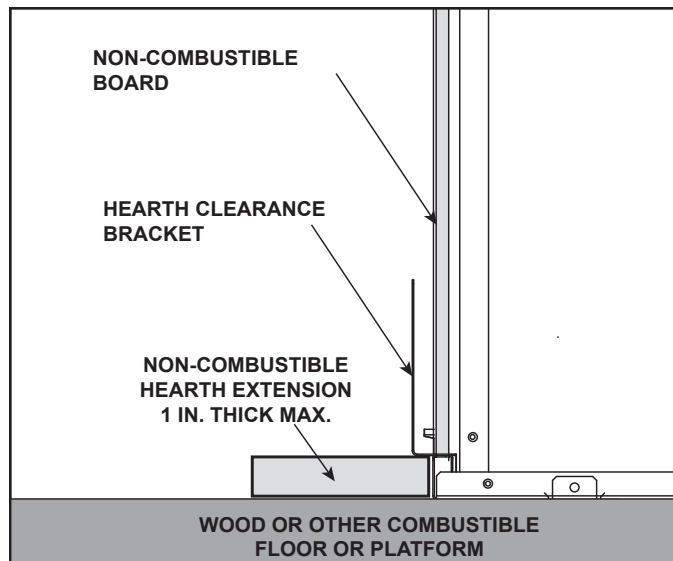

Figure 3.8 Appliance Installed on Combustible Surface  
Non-Combustible Hearth Extension REQUIRED.

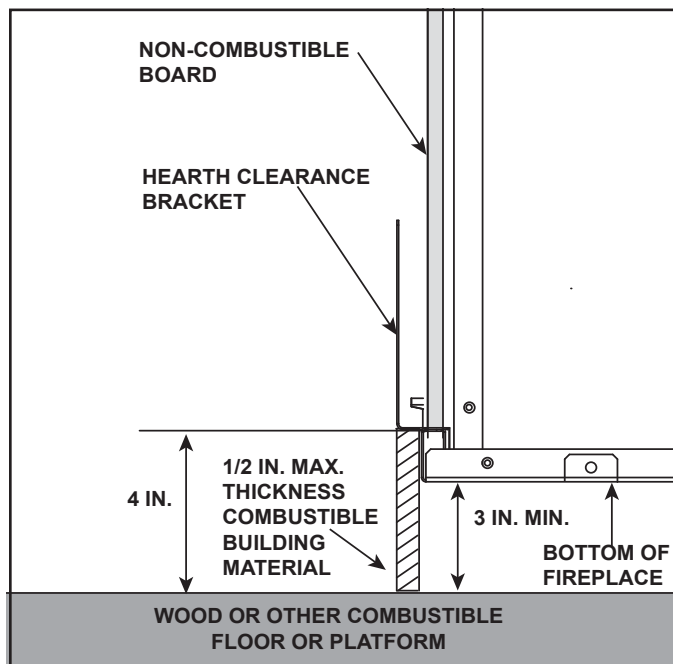

Figure 3.9 Appliance Raised a Minimum of 3 Inches Above  
Combustible Surface.  
Non-Combustible Hearth Extension NOT REQUIRED.

# 4 Termination Location and Vent Information

## A. Vent Termination Minimum Clearances

**WARNING**

Fire Risk.  
Maintain vent clearance to combustibles as specified.

- **DO NOT** pack air space with insulation or other materials.

Failure to keep insulation or other materials away from vent pipe may cause overheating and fire.

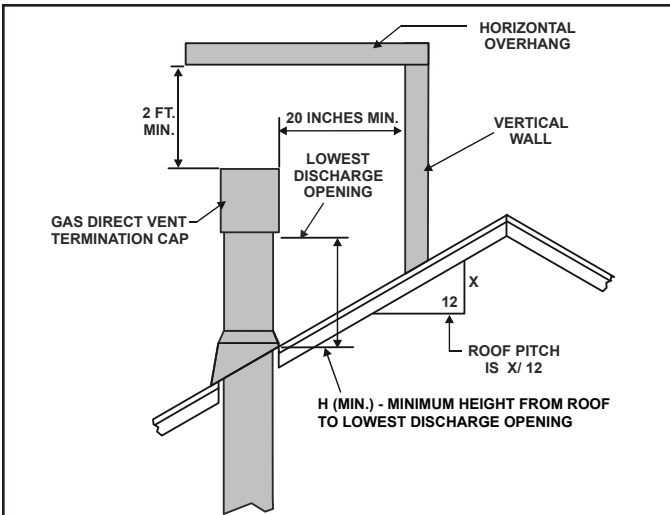

Roof Pitch	H (Min.) Ft.
Flat to 6/12.....	1.0*
Over 6/12 to 7/12.....	1.25*
Over 7/12 to 8/12.....	1.5*
Over 8/12 to 9/12.....	2.0*
Over 9/12 to 10/12.....	2.5*
Over 10/12 to 11/12.....	3.25
Over 11/12 to 12/12.....	4.0
Over 12/12 to 14/12.....	5.0
Over 14/12 to 16/12.....	6.0
Over 16/12 to 18/12.....	7.0
Over 18/12 to 20/12.....	7.5
Over 20/12 to 21/12.....	8.0

\* 3 foot minimum in snow regions

**Figure 4.1 Minimum Height From Roof To Lowest Discharge Opening**

A	B
6 in. (minimum) up to 20 in. 152 mm/508 mm	18 in. minimum 457 mm
20 in. and over	0 in. minimum

\* If using decorative cap cover(s), this distance may need to be increased. Refer to the installation instructions supplied with the decorative cap cover.

\*\* In a staggered installation with both gas and wood or fuel oil terminations, the wood or fuel oil termination cap must be higher than the gas termination cap.

**Figure 4.2 Staggered Termination Caps**

**NOTICE: LUX36 and LUX42:**

Horizontal vent terminations ARE approved for installation with vinyl siding and/or vinyl soffits provided the VPK-DV (vinyl protector kit) is installed. Permanent damage to vinyl siding or vinyl soffits may occur.

## B. Chimney Diagram

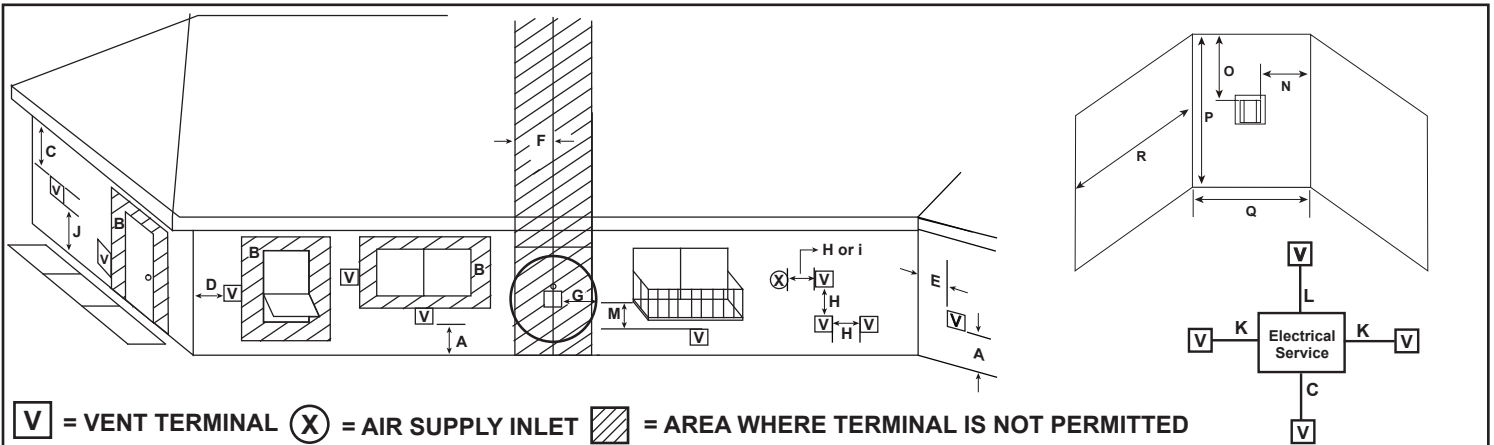

**V** = VENT TERMINAL **X** = AIR SUPPLY INLET = AREA WHERE TERMINAL IS NOT PERMITTED

- A = 12 inches.....clearances above grade, veranda, porch, deck or balcony
- B = 12 inches.....clearance to window or door that may be opened, or to permanently closed window
- C = 18 inches.....clearance below an unventilated/ventilated soffit with non-vinyl siding
- = 18 inches.....clearance below an unventilated/ventilated soffit with vinyl siding. Requires a vinyl protector kit (VPK-DV)
- = 42 inches.....clearance below a vinyl soffit with non-vinyl siding
- = 42 inches.....clearance below a vinyl soffit with vinyl siding. Requires a vinyl protector kit (VPK-DV)
- D = 6 inches.....clearance to outside corner
- E = 6 inches.....clearance to inside corner
- F = 3 ft. (Canada).....not to be installed above a gas meter/regulator assembly within 3 feet horizontally from the center-line of the regulator
- G = 3 ft.....clearance to gas service regulator vent outlet
- H = 12 inches.....clearance to non-mechanical (unpowered) air supply inlet, combustion air inlet or direct-vent termination
- i = 3 ft. (U.S.A.)  
6 ft. (Canada).....clearance to a mechanical (powered) air supply inlet

All mechanical air intakes within 10 feet of a termination cap must be a minimum of 3 feet below termination.

J = 7 ft..... On **public** property: clearance above paved sidewalk or a paved driveway.

A vent shall not terminate directly above a sidewalk or paved driveway which is located between two single family dwellings and serves both dwellings.

K = 6 inches.....clearance from sides of electrical service

L = 12 inches.....clearance above electrical service  
Location of the vent termination must not interfere with access to the electrical service.

M = 18 inches ..... clearance under veranda, porch, deck, balcony or overhang

42 inches .....vinyl or composite overhang  
Permitted when veranda, porch, deck or balcony is fully open on a minimum of 2 sides beneath the floor.

**Figure 4.3 Minimum Clearances for Termination**

- N = 6 inches .....non-vinyl sidewalls  
12 inches .....vinyl sidewalls
- O = 18 inches .....clearance below an unventilated/ventilated soffit with non-vinyl siding
- = 18 inches.....clearance below an unventilated/ventilated soffit with vinyl siding. Requires a vinyl protector kit (VPK-DV)
- = 42 inches.....clearance below a vinyl soffit with non-vinyl siding
- = 42 inches.....clearance below a vinyl soffit with vinyl siding. Requires a vinyl protector kit (VPK-DV)
- P = 8 ft.

	$Q_{MIN}$	$R_{MAX}$
1 cap	3 feet	2 x $Q_{ACTUAL}$
2 caps	6 feet	1 x $Q_{ACTUAL}$
3 caps	9 feet	2/3 x $Q_{ACTUAL}$
4 caps	12 feet	1/2 x $Q_{ACTUAL}$
$Q_{MIN} = \# \text{ termination caps } \times 3$ $R_{MAX} = (2 / \# \text{ termination caps}) \times Q_{ACTUAL}$		

Measure vertical clearances from this surface.

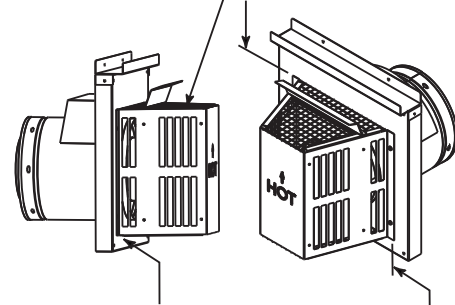

Measure horizontal clearances from this surface.

**CAUTION! Risk of Burns!** Termination caps are **HOT**, consider proximity to doors, traffic areas or where people may pass or gather (sidewalk, deck, patio, etc.). Listed cap shields available. Contact your dealer.

- Local codes or regulations may require different clearances.
- Vent system termination is **NOT** permitted in screened porches.
- Vent system termination is permitted in porch areas with two or more sides open.
- Hearth & Home Technologies assumes no responsibility for the improper performance of the appliance when the venting system does not meet these requirements.
- Vinyl protection kits are required for use with vinyl siding.

### C. Approved Pipe

This appliance is approved for use with Hearth & Home Technologies DVP venting systems. Refer to Section 12.A for vent component information and dimensions.

**DO NOT** mix pipe, fittings or joining methods from different manufacturers.

The pipe is tested to be run inside an enclosed wall. There is no requirement for inspection openings at each joint within the wall.

**WARNING! Risk of Fire or Asphyxiation.** This appliance requires a separate vent. **DO NOT** vent to a pipe serving a separate solid fuel burning appliance.

### D. Use of Elbows

Diagonal runs have both vertical and horizontal vent aspects when calculating the effects. Use the rise for the vertical aspect and the run for the horizontal aspect. See Figure 4.4.

Two 45° elbows may be used in place of one 90° elbow. On 45° runs, one foot of diagonal is equal to 8-1/2 in. (216 mm) horizontal run and 8-1/2 in. (216 mm) vertical run. A length of straight pipe is allowed between two 45° elbows. See Figure 4.4.

Figure 4.5 shows the vertical and horizontal offsets for DVP or SLP elbows.

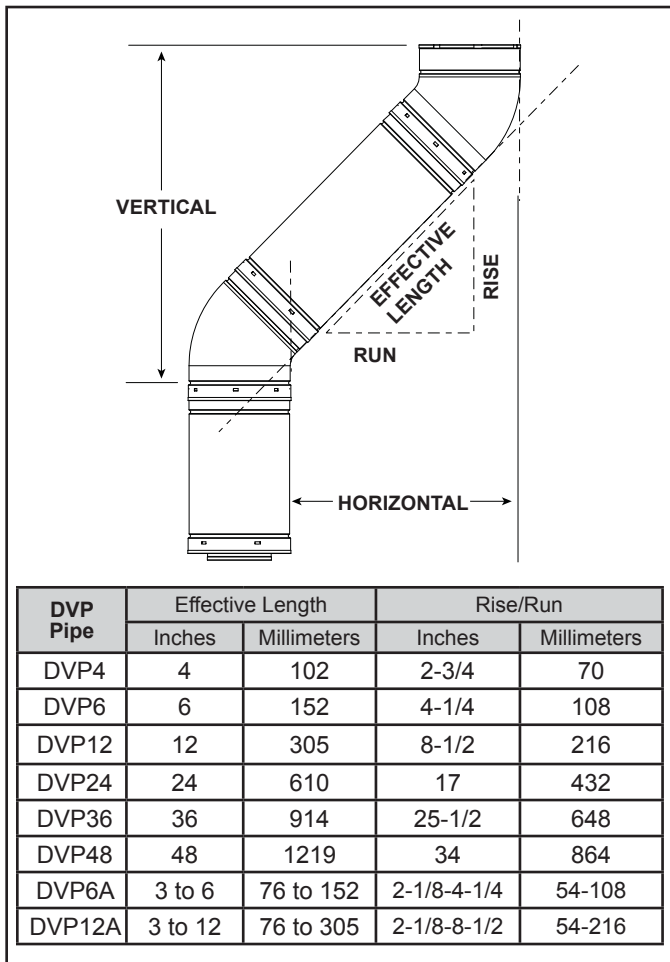

Figure 4.4

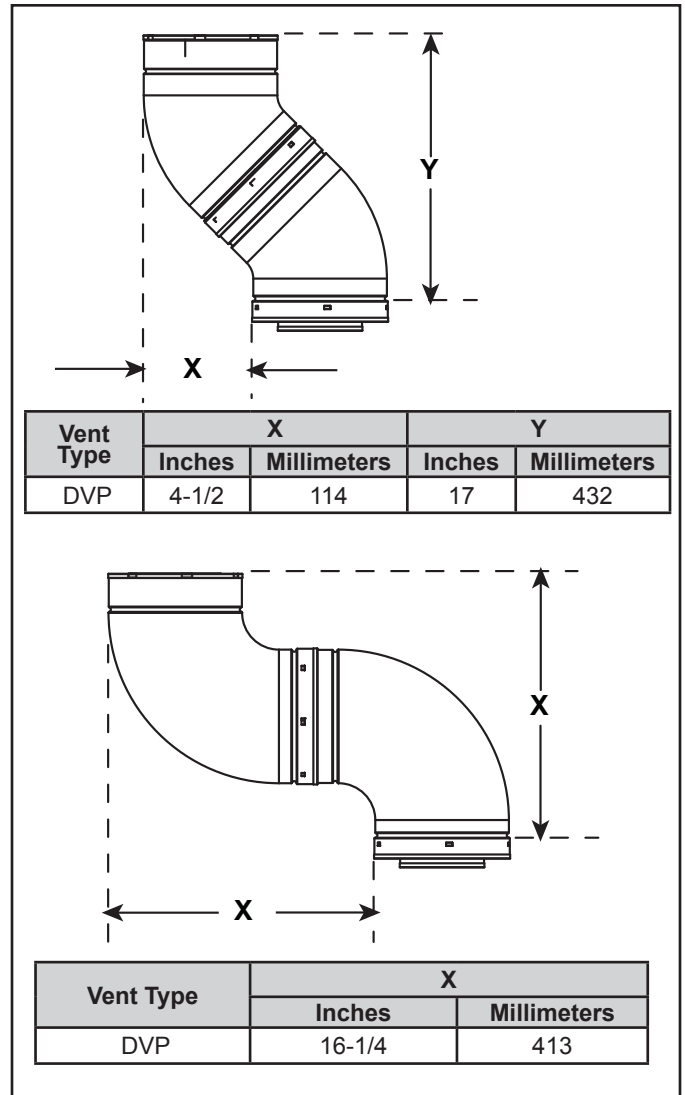

Figure 4.5 Vertical and Horizontal Offset for DVP and SLP Elbows

### E. Measuring Standards

Vertical and horizontal measurements listed in the vent diagrams were made using the following standards:

- Pipe measurements are shown using the effective length of pipe. See Section 12.A for information on effective length of pipe components.
- Horizontal terminations are measured to the outside mounting surface (flange of termination cap) (see Figure 4.3).
- Vertical terminations are measured to bottom of termination cap.
- Horizontal pipe installed level with no rise.

**Note:** Model LUX42 (NG) must have 48 inches minimum vertical vent before attaching any elbow to the appliance.



## F. Vent Diagrams

**WARNING! Risk of Fire.** This appliance requires a minimum of 24 inches of vertical venting before attaching any elbow to the appliance. **DO NOT** attach elbow directly to the appliance.

General Rules:

- This appliance is approved for use with Hearth & Home Technologies DVP venting systems ONLY.
- When penetrating a combustible wall, a wall shield firestop must be installed.
- When penetrating a combustible ceiling, a ceiling firestop must be installed.
- This appliance requires a minimum of 24 inches of vertical pipe attached directly to the appliance starting collar before attaching a 90 degree or 45 degree elbow.

### Top Vent - Horizontal Termination

#### One Elbow

**WARNING! Risk of Fire!**

- LUX36 requires a minimum of 24 inches of vertical venting before attaching any elbow to the appliance.
- LUX42 requires a minimum of 48 inches of vertical venting before attaching any elbow to the appliance.

**DO NOT attach elbow directly to the appliance.**

**Note:** Flue restrictor is permitted ONLY on 30 ft. minimum vertical runs with no elbows.

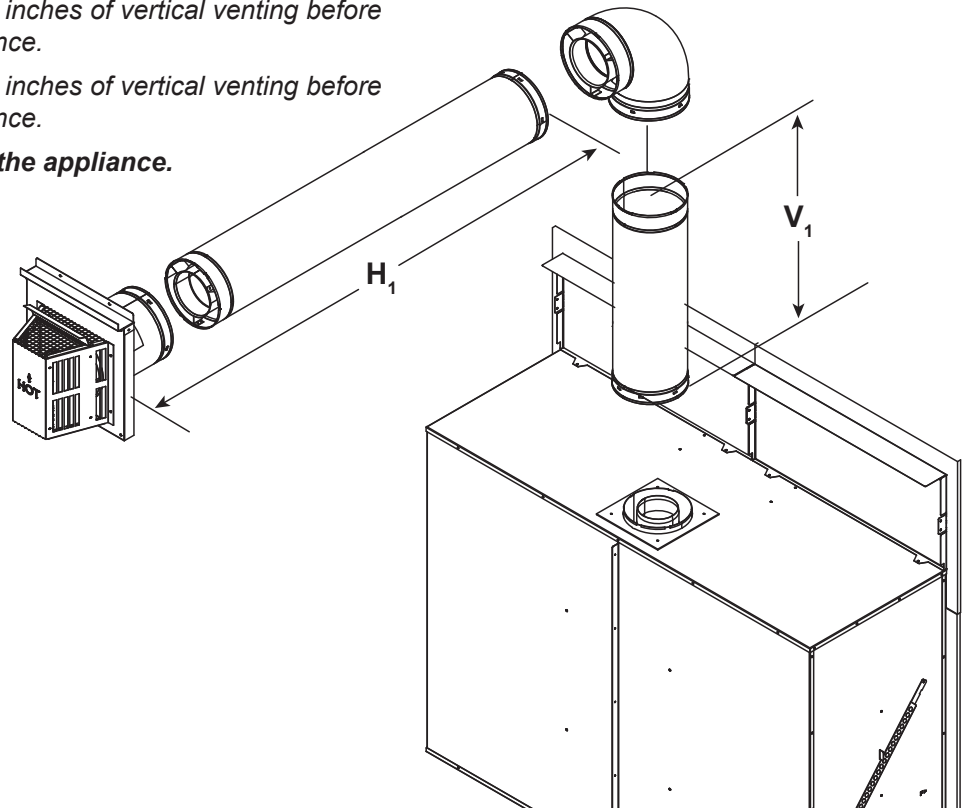

LUX36			
V <sub>1</sub> Minimum		H <sub>1</sub> Maximum	
2 ft	610 mm	17 in*	432 mm
3 ft	914 mm	2 ft	610 mm
4 ft	1.2 m	4 ft	1.2 m
5 ft	1.5 m	9 ft	2.7 m
6 ft	1.8 m	12 ft	3.7 m
7 ft	2.1 m	14 ft	4.3 m
10 ft	3.0 m	20 ft	6.1 m
20 ft	6.1 m	40 ft	12.2 m
After V <sub>1</sub> = 6 ft then H <sub>1</sub> = 2 x V ft Maximum V <sub>1</sub> + H <sub>1</sub> = 60 ft Maximum *when used with approved termination caps			

LUX42			
V <sub>1</sub> Minimum		H <sub>1</sub> Maximum	
4 ft	1.2 m	17 in*	432 mm
5 ft	1.5 m	2 ft	610 mm
6 ft	1.8 m	9 ft	2.7 m
7 ft	2.1 m	14 ft	4.3 m
10 ft	3.0 m	20 ft	6.1 m
20 ft	6.1 m	40 ft	12.2 m
After V <sub>1</sub> = 6 ft then H <sub>1</sub> = 2 x V ft Maximum V <sub>1</sub> + H <sub>1</sub> = 60 ft Maximum *when used with approved termination caps			

Figure 4.6

## Top Vent - Horizontal Termination - (continued)

### → Two Elbows

#### **WARNING! Risk of Fire!**

- LUX36 requires a minimum of 36 inches of vertical venting before attaching any elbow to the appliance for the venting configuration in Figure 7.4.
- LUX42 requires a minimum of 48 inches of vertical venting before attaching any elbow to the appliance.

**DO NOT attach elbow directly to the appliance.**

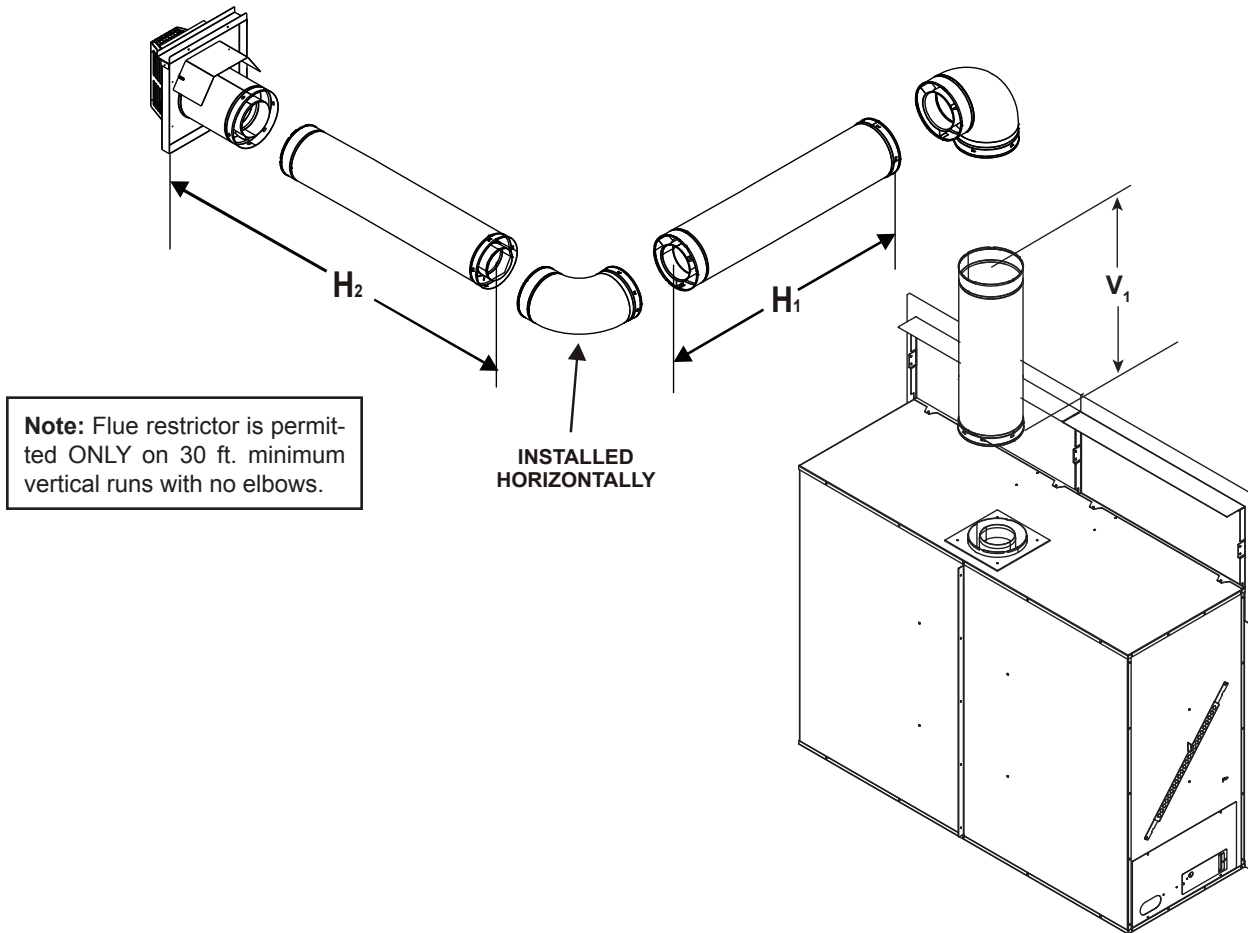

LUX36			
V <sub>1</sub> Minimum		H <sub>1</sub> + H <sub>2</sub>	
3 ft	914 mm	18 in	457 mm
4 ft	1.2 m	3 ft	914 mm
5 ft	1.5 m	7 ft	2.1 m
6 ft	1.8 m	10 ft	3.0 m
7 ft	2.1 m	14 ft	3.7 m
8 ft	2.4 m	16 ft	4.9
9 ft	2.7 m	18 ft	5.5 m
10 ft	3.0 m	20 ft	6.1 m
V <sub>1</sub> + H <sub>1</sub> + H <sub>2</sub> = 60 ft Maximum H <sub>1</sub> + H <sub>2</sub> = 20 ft Maximum			

LUX42			
V <sub>1</sub> Minimum		H <sub>1</sub> + H <sub>2</sub>	
4 ft	1.2 m	17 in	432 mm
5 ft	1.5 m	2 ft	610 mm
6 ft	1.8 m	9 ft	2.7 m
7 ft	2.1 m	14 ft	3.7 m
8 ft	2.4 m	16 ft	4.9 m
9 ft	2.7 m	18 ft	5.5 m
10 ft	3.0 m	20 ft	6.1 m
V <sub>1</sub> + H <sub>1</sub> + H <sub>2</sub> = 60 ft Maximum H <sub>1</sub> + H <sub>2</sub> = 20 ft Maximum			

Figure 4.7

## → Top Vent - Horizontal Termination - (continued)

### Three Elbows

#### **WARNING! Risk of Fire!**

- LUX36 requires a minimum of 24 inches of vertical venting before attaching any elbow to the appliance.
- LUX42 requires a minimum of 48 inches of vertical venting before attaching any elbow to the appliance.

**DO NOT attach elbow directly to the appliance.**

**Note:** Flue restrictor is permitted ONLY on 30 ft. minimum vertical runs with no elbows.

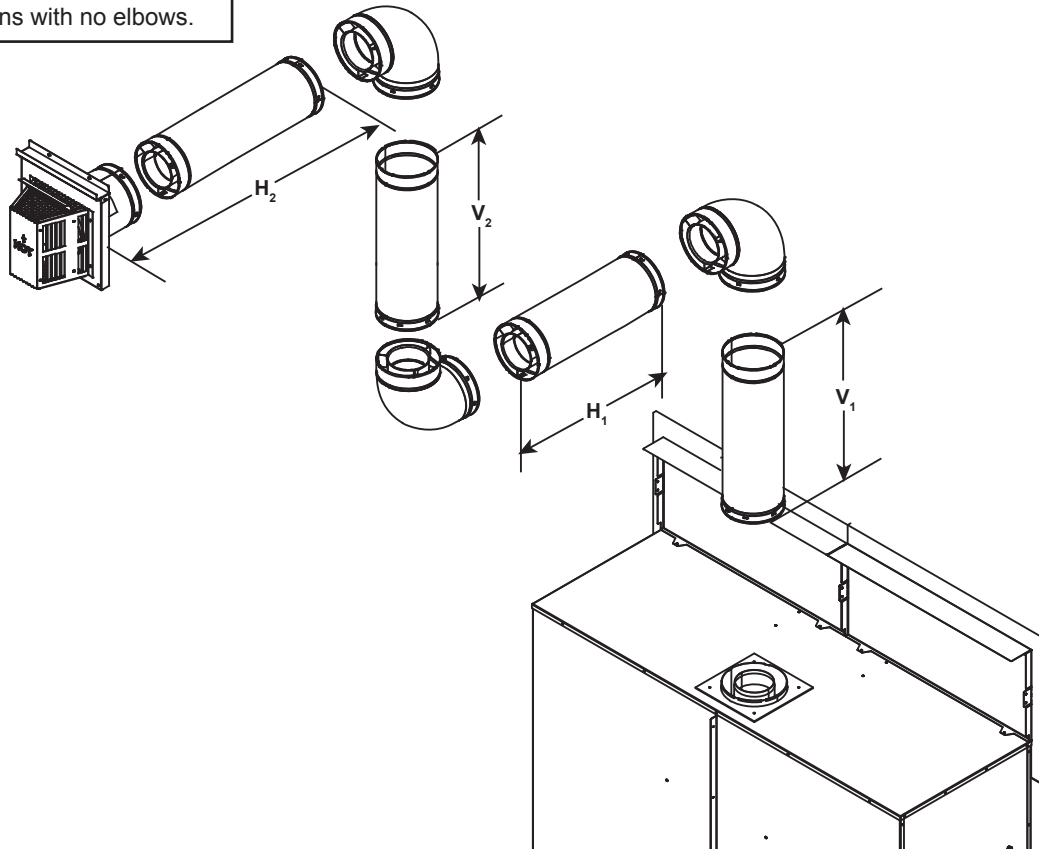

LUX36					
$V_1$		$H_1$ Maximum		$V_2$	$H_2$
2 ft	610 mm	17 in	432 mm	*	$H_2 \text{ Max} = 2 \times V_2$
3 ft	914 mm	2 ft	610 mm	*	$H_2 \text{ Max} = 2 \times V_2$
4 ft	1.2 m	4 ft	1.2 m	*	$H_2 \text{ Max} = 2 \times V_2$
5 ft	1.5 m	9 ft	2.7 m	*	$H_2 \text{ Max} = 2 \times V_2$
6 ft	1.8 m	12 ft	3.7 m	*	$H_2 \text{ Max} = 2 \times V_2$
7 ft	2.1 m	14 ft	4.3 m	*	$H_2 \text{ Max} = 2 \times V_2$
10 ft	3.0 m	20 ft	6.1 m	*	$H_2 \text{ Max} = 2 \times V_2$
$V_1 + H_1$ must be adhered to. * $V_2$ has no specific restrictions EXCEPT, $V_{\text{total}} + H_{\text{total}}$ cannot exceed 60 ft Maximum					

LUX42					
$V_1$		$H_1$ Maximum		$V_2$	$H_2$
4 ft	1.2 m	17 in	432 mm	*	$H_2 \text{ Max} = 2 \times V_2$
5 ft	1.5 m	2 ft	610 mm	*	$H_2 \text{ Max} = 2 \times V_2$
6 ft	1.8 m	9 ft	2.7 m	*	$H_2 \text{ Max} = 2 \times V_2$
7 ft	2.1 m	14 ft	4.3 m	*	$H_2 \text{ Max} = 2 \times V_2$
10 ft	3.0 m	20 ft	6.1 m	*	$H_2 \text{ Max} = 2 \times V_2$
$V_1 + H_1$ must be adhered to. * $V_2$ has no specific restrictions EXCEPT, $V_{\text{total}} + H_{\text{total}}$ cannot exceed 60 ft Maximum					

Figure 4.8

## Top Vent - Vertical Termination

### No Elbow

**Note:** Flue restrictor is permitted ONLY on 30 ft. minimum vertical runs with no elbows.

$V_1 = 50$  ft. Max. (15.2 m)  
 $V_1 = 2$  ft. Min. (610 mm) LUX36  
 $V_1 = 4$  ft. Min. (1.2 m) LUX42

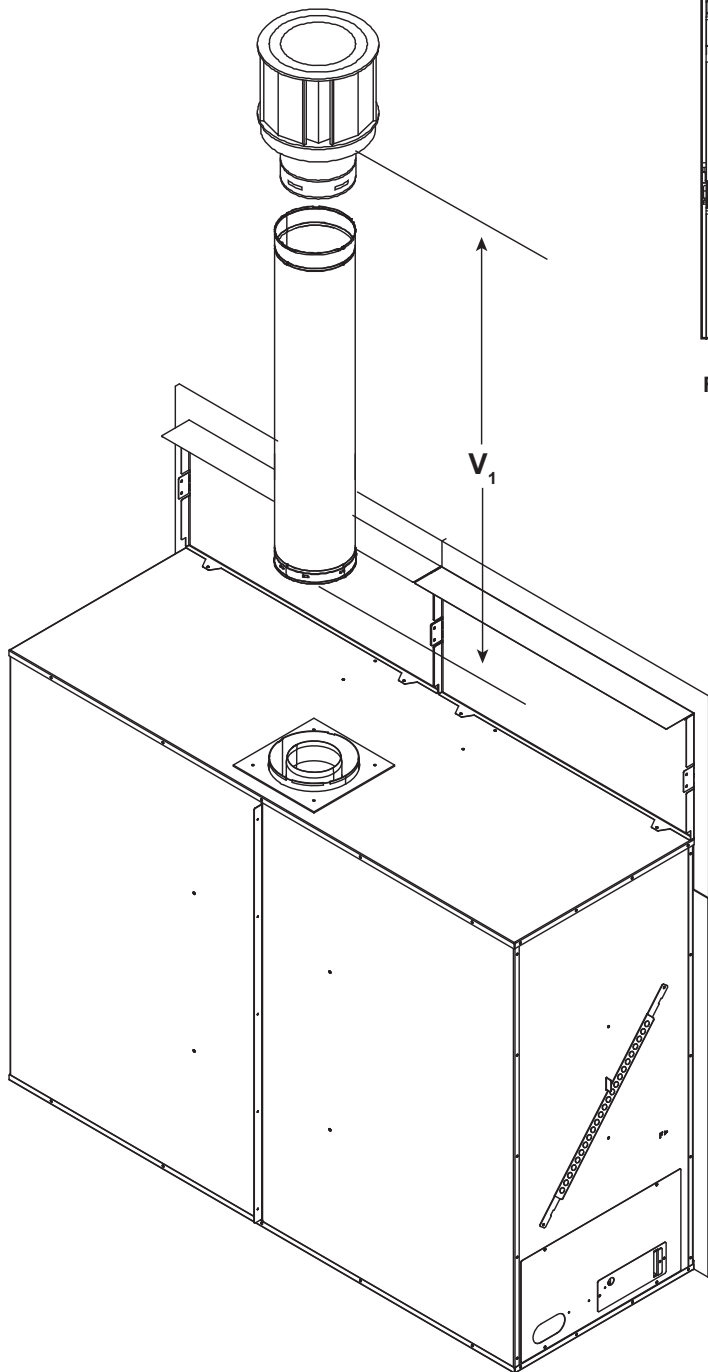

**NOTE:** Flue Restrictor ships in manual bag assembly.

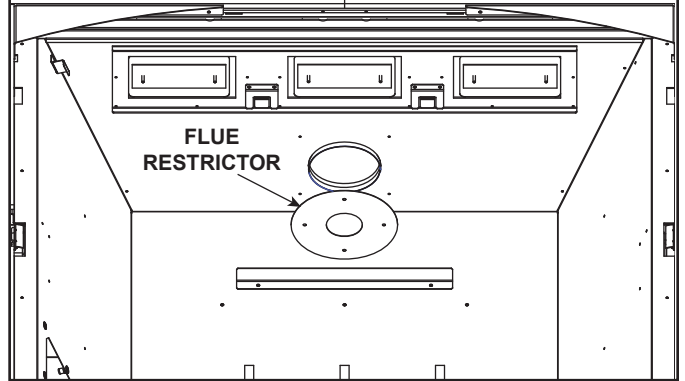

Figure 7.7 Flue Restrictor Installation

Figure 4.9

# Top Vent - Horizontal Termination

## 2 ELBOWS

### WARNING! Risk of Fire!

- LUX36 requires a minimum of 24 inches of vertical venting before attaching any elbow to the appliance.
- LUX42 requires a minimum of 48 inches of vertical venting before attaching any elbow to the appliance.

**DO NOT attach elbow directly to the appliance.**

**Note:** Flue restrictor is permitted ONLY on 30 ft. minimum vertical runs with no elbows.

LUX36				
V <sub>1</sub>		H <sub>1</sub> Maximum		V <sub>2</sub>
2 ft	610 mm	17 in.	432 mm	*
3 ft	914 mm	3 ft	914 mm	*
4 ft	1.2 m	4 ft	1.2 m	*
5 ft	1.5 m	9 ft	2.7 m	*
6 ft	1.8 m	12 ft	3.7 m	*

$V_1 + V_2 + H_1 = 60 \text{ ft (18.3 m) Max.}$   
 \*No specific restrictions on this value EXCEPT  
 $V_1 + V_2 + H_1$  cannot exceed 60 ft (18.3 m).  
 After  $V_1 = 6 \text{ ft}$ , then  $H_1 \text{ Max.} = V_1 \times 2$

LUX42				
V <sub>1</sub>		H <sub>1</sub> Maximum		V <sub>2</sub>
4 ft	1.2 m	17 in.	432 mm	*
5 ft	1.5 m	2 ft	610 mm	*
6 ft	1.8 m	9 ft	2.7 m	*

$V_1 + V_2 + H_1 = 60 \text{ ft (18.3 m) Max.}$   
 \*No specific restrictions on this value EXCEPT  
 $V_1 + V_2 + H_1$  cannot exceed 60 ft (18.3 m).  
 After  $V_1 = 6 \text{ ft}$ , then  $H_1 \text{ Max.} = V_1 \times 2$

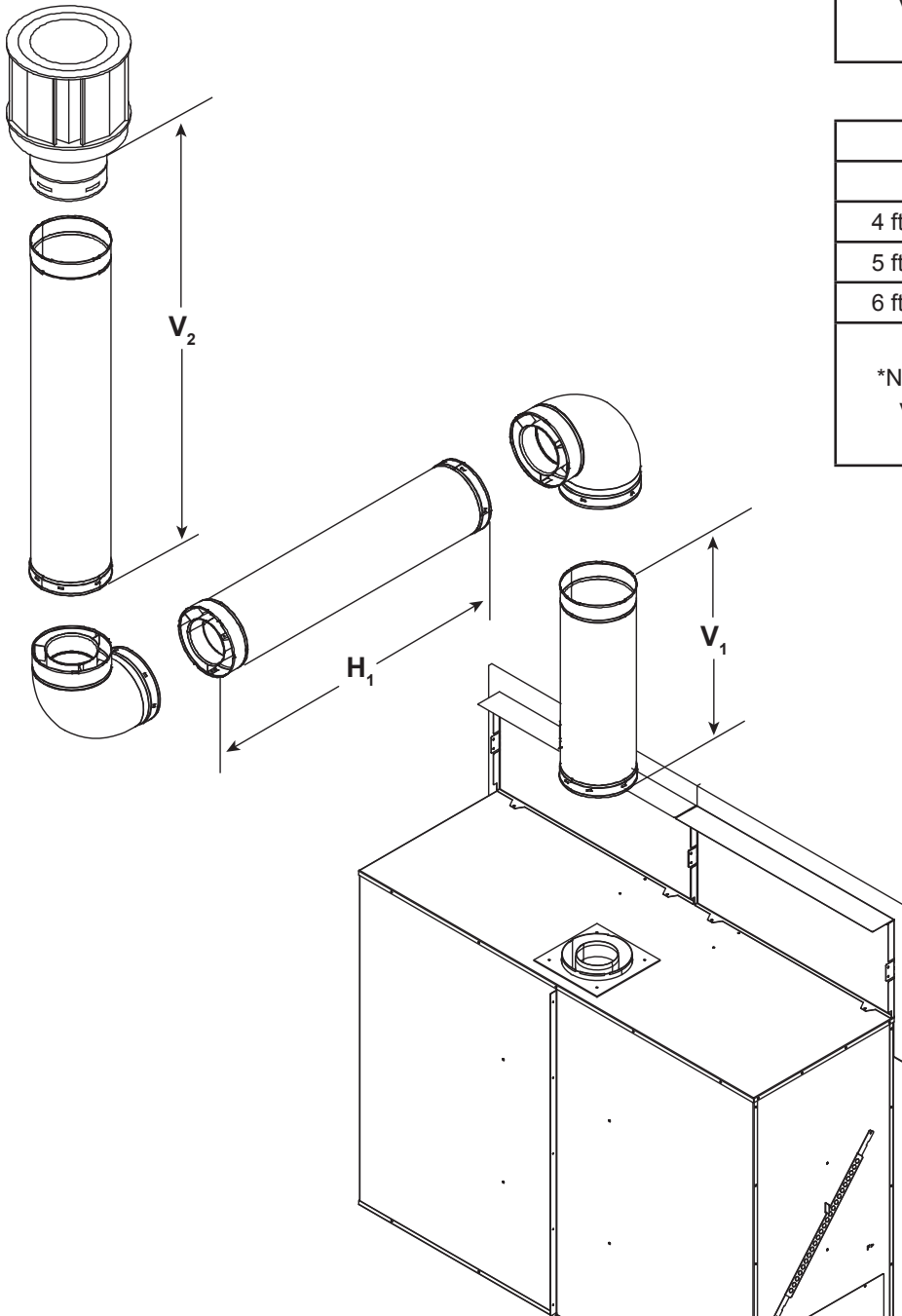

Figure 4.10

## → Top Vent - Horizontal Termination - (continued)

### Three Elbows

#### **WARNING! Risk of Fire!**

- LUX36 requires a minimum of 24 inches of vertical venting before attaching any elbow to the appliance.
- LUX42 requires a minimum of 48 inches of vertical venting before attaching any elbow to the appliance.

**DO NOT attach elbow directly to the appliance.**

**Note:** Flue restrictor is permitted ONLY on 30 ft. minimum vertical runs with no elbows.

LUX36				
$V_1$		$H_1$ Maximum		$V_2$
2 ft	610 mm	17 in.	432 mm	*
3 ft	914 mm	3 ft	914 mm	*
4 ft	1.2 m	4 ft	1.2 m	*
5 ft	1.5 m	9 ft	2.7 m	*
6 ft	1.8 m	12 ft	3.7 m	*

$V_1 + V_2 + H_1 + H_2 = 60$  ft (18.3 m) Max.  
 \*No specific restrictions on this value EXCEPT  
 $V_1 + V_2 + H_1$  cannot exceed 60 ft (18.3 m).  
 After  $V_1 = 6$  ft, then  $H_1$  Max. =  $V_1 \times 2$

LUX42				
$V_1$		$H_1$ Maximum		$V_2$
4 ft	1.2 m	17 in.	432 mm	*
5 ft	1.5 m	2 ft	610 mm	*
6 ft	1.8 m	9 ft	2.7 m	*

$V_1 + V_2 + H_1 + H_2 = 60$  ft (18.3 m) Max.  
 \*No specific restrictions on this value EXCEPT  
 $V_1 + V_2 + H_1 + H_2$  cannot exceed 60 ft (18.3 m).  
 After  $V_1 = 6$  ft, then  $H_1$  Max. =  $V_1 \times 2$

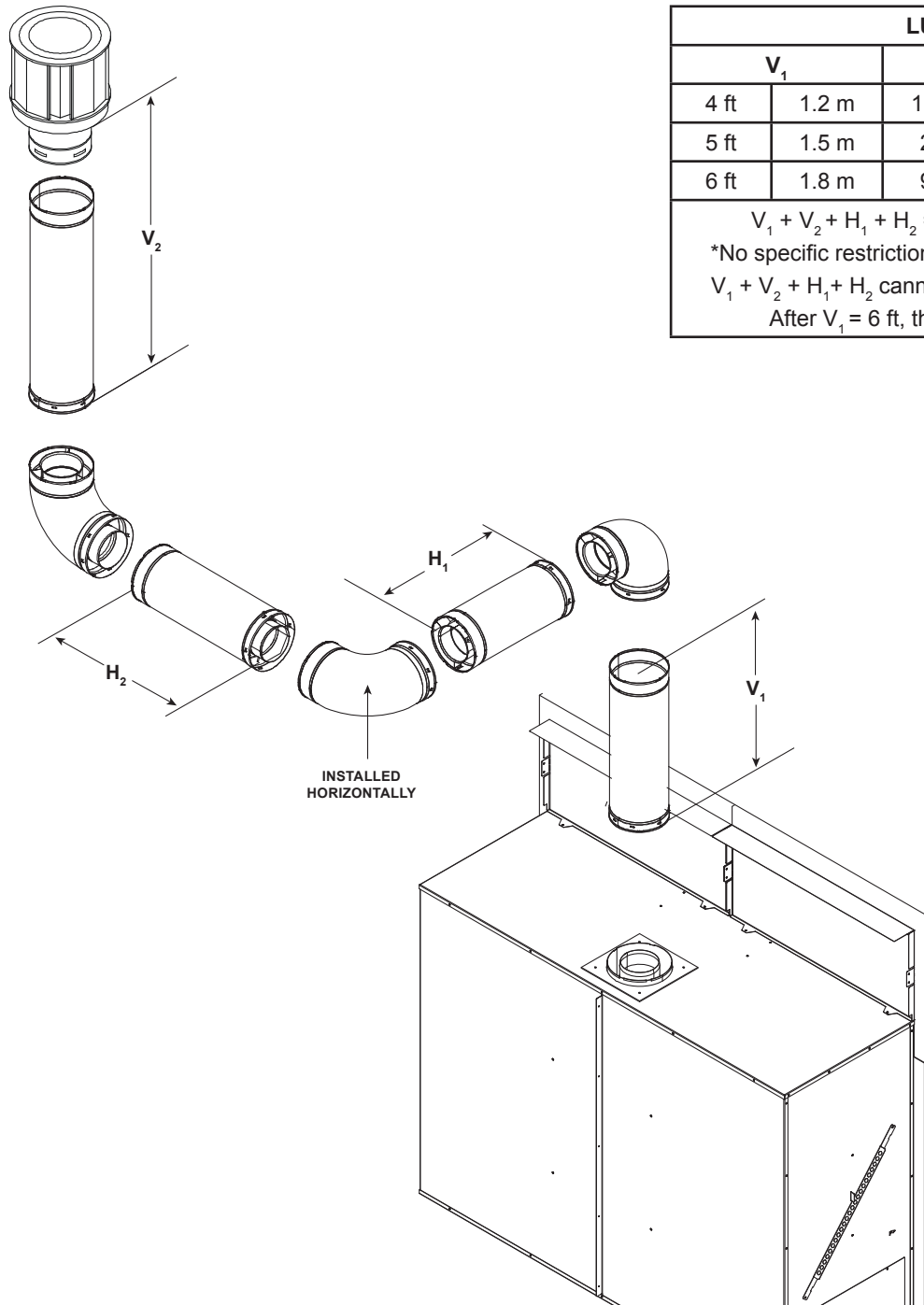

Figure 4.11

## G. PVK-80 and PVI-SLP Information

This section provides specific detail for installation of LUX36 and LUX42 models with approved power vent kits. Follow instructions included with the PVK-80 or PVI-SLP power vent kits.

See Table 4.1 below for approved Power Venting options for LUX models.

**WARNING! Risk of Fire!** Use ONLY Hearth & Home Technologies-approved power venting systems with this appliance. Use of power venting systems not approved by Hearth & Home Technologies may cause fireplace to overheat.

	PVK-80	PVI-SLP
LUX36	APPROVED	APPROVED
LUX42	APPROVED	APPROVED

Table 4.1

The power vent draft flow must be adjusted and set per the specifications in Table 4.2. Refer to the instructions provided with the PVK-80 and PVI-SLP for more specific information.

**PVK-80:** The exhaust control lever reduces the draft as it is opened. Open the exhaust control lever to FULL OPEN. See Figure 4.12. Secure the exhaust control lever to the power vent housing with the sheet metal screw.

**Note:** When using a PVK-80 only, the PVK80-PLUS Kit must be installed by a qualified service technician. Contact your dealer to order.

**PVI-SLP:** The baffle adjustment is measured using the holes on the indicator bar of the PVI-SLP baffle. This bar raises as the baffle is opened and lowers as the baffle is closed. Adjust the baffle by turning the screw located in the motor enclosure. See Figure 4.13 and 4.14.

**WARNING! Risk of Explosion!** Follow instructions to set draft flow. Incorrect setting may impair burner performance and/or cause delayed ignition.

	PVK-80 Exhaust Control Lever	PVI-SLP Baffle Adjustment Setting
LUX36	FULL OPEN	3 Holes Visible
LUX42	FULL OPEN	2 Holes Visible

Table 4.2



Figure 4.10 PVK-80 Control Lever Adjustment - Open

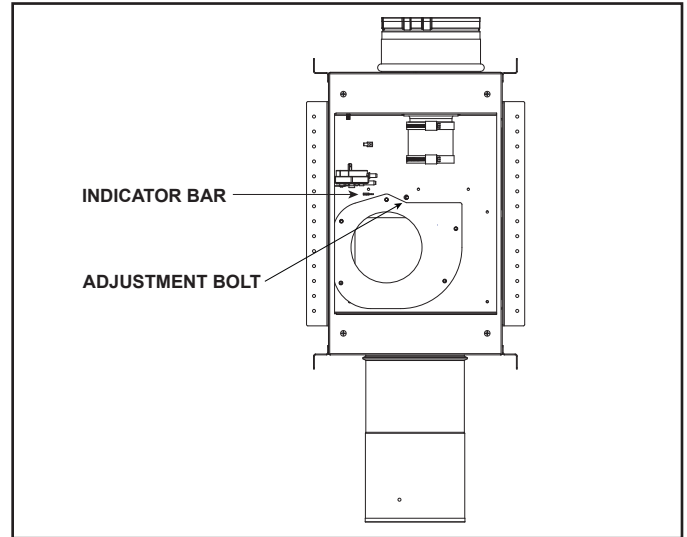

Figure 4.11 Baffle Adjustment Location - PVI-SLP

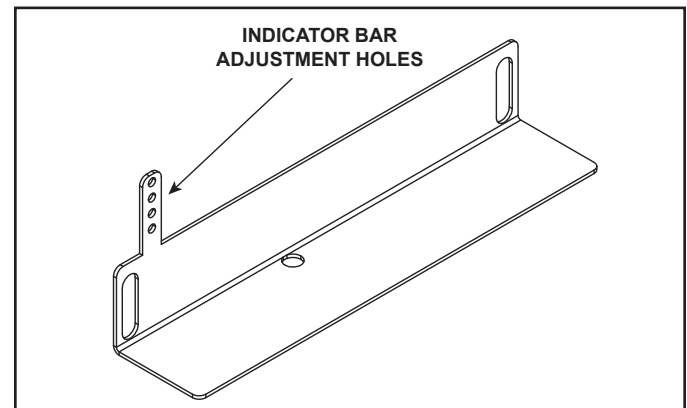

Figure 4.12 Baffle Adjustment - PVI-SLP

# 5 Vent Clearances and Framing

## A. Pipe Clearances to Combustibles

**WARNING! Risk of Fire! Maintain air space clearance to vent. DO NOT pack insulation or other combustibles:**

- Between ceiling firestops
- Between wall shield firestops
- Around vent system

Failure to keep insulation or other material away from vent pipe may cause overheating and fire.

Note: Heat shields MUST overlap by a minimum of 1-1/2 in. (38 mm).  
 • DVP heat shield - designed to be used on a wall 4 in. to 7-1/4 in. (102 mm to 184 mm) thick.  
 • If wall thickness is less than 4 in. the existing heat shields must be field trimmed. If wall thickness is greater than 7-1/4 in. a DVP-HSM-B will be required.  
 • If wall thickness is less than 4-3/8 the existing heat shields must be field trimmed. If wall thickness is greater than 7-5/8 in. a DVP-HSM-B will be required.

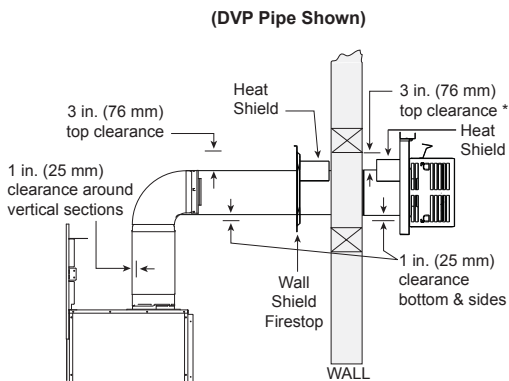

Figure 5.1 Horizontal Venting Clearances To Combustible Materials

## B. Wall Penetration Framing/Firestops

### Combustible Wall Penetration

Whenever a combustible wall is penetrated, you must frame a hole for the wall shield firestop(s). The wall shield firestop maintains minimum clearances and prevents cold air infiltration.

- The opening must be framed on all four sides using the same size framing materials as those used in the wall construction.
- DVP pipe - A wall shield firestop is required on one side only on interior walls. If your local inspector requires a wall shield firestop on both sides, then both wall shield firestops must have a heat shield (refer to Section 12.A.) attached to them.
- See Section 7.F. for information for regarding the installation of a horizontal termination cap.

### Non-Combustible Wall Penetration

If the hole being penetrated is surrounded by non-combustible materials such as concrete, a hole with diameter one inch greater than the pipe is acceptable.

Whenever a non-combustible wall is penetrated, the wall shield firestop is only required on one side and no heat shield is necessary.

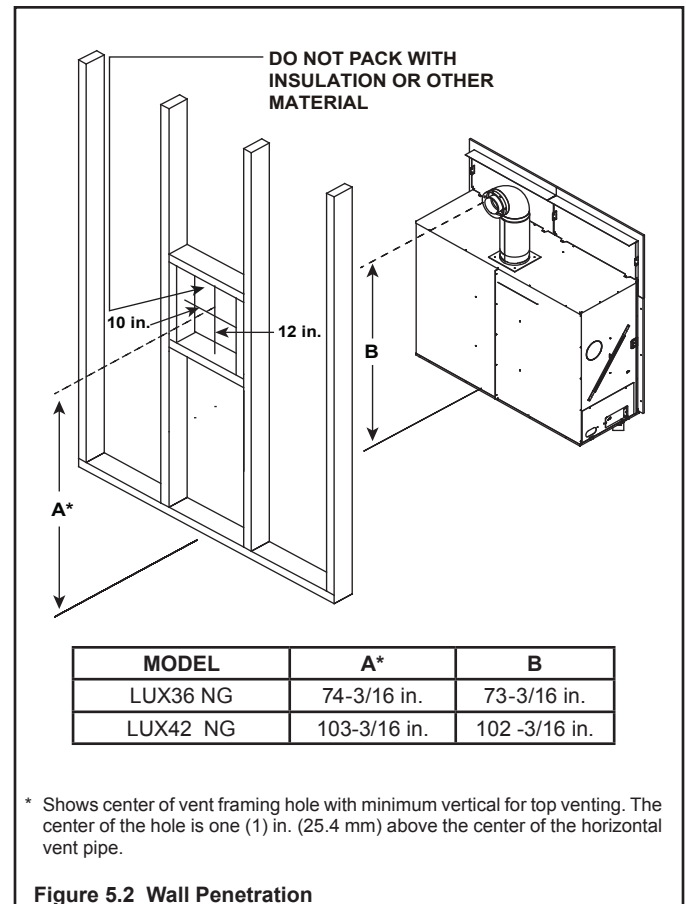

Figure 5.2 Wall Penetration



### C. Ceiling Firestop/Floor Penetration Framing

A ceiling firestop **MUST** be used between floors and attics.

- **DVP pipe only** - Frame an opening 10 in. by 10 in. (254 mm by 254 mm) whenever the vent penetrates a ceiling/floor (see Figure 5.3).
- Frame the area with the same sized lumber as used in ceiling/floor joist.
- The ceiling firestop may be installed above or below the ceiling joists when installed with an attic insulation shield. It must be under joists between floors that are not insulated. Refer to Figure 5.4.
- Secure with three fasteners on each side.

**WARNING! Risk of Fire! DO NOT pack insulation around the vent. Insulation must be kept back from the pipe to prevent overheating.**

### → D. Install Attic Insulation Shield

**WARNING! Fire Risk. DO NOT allow loose materials or insulation to touch vent. Hearth & Home Technologies requires the use of an attic shield.**

The International Fuel Gas Code requires an attic shield constructed of 26 gauge minimum steel that extends at least 2 in. (51 mm) above insulation.

- Attic insulation shields must meet specified clearances to combustible materials and be secured in place.
- An attic insulation shield kit is available from Hearth & Home Technologies. Contact your dealer to order. Install attic insulation shield according to instructions included with kit.

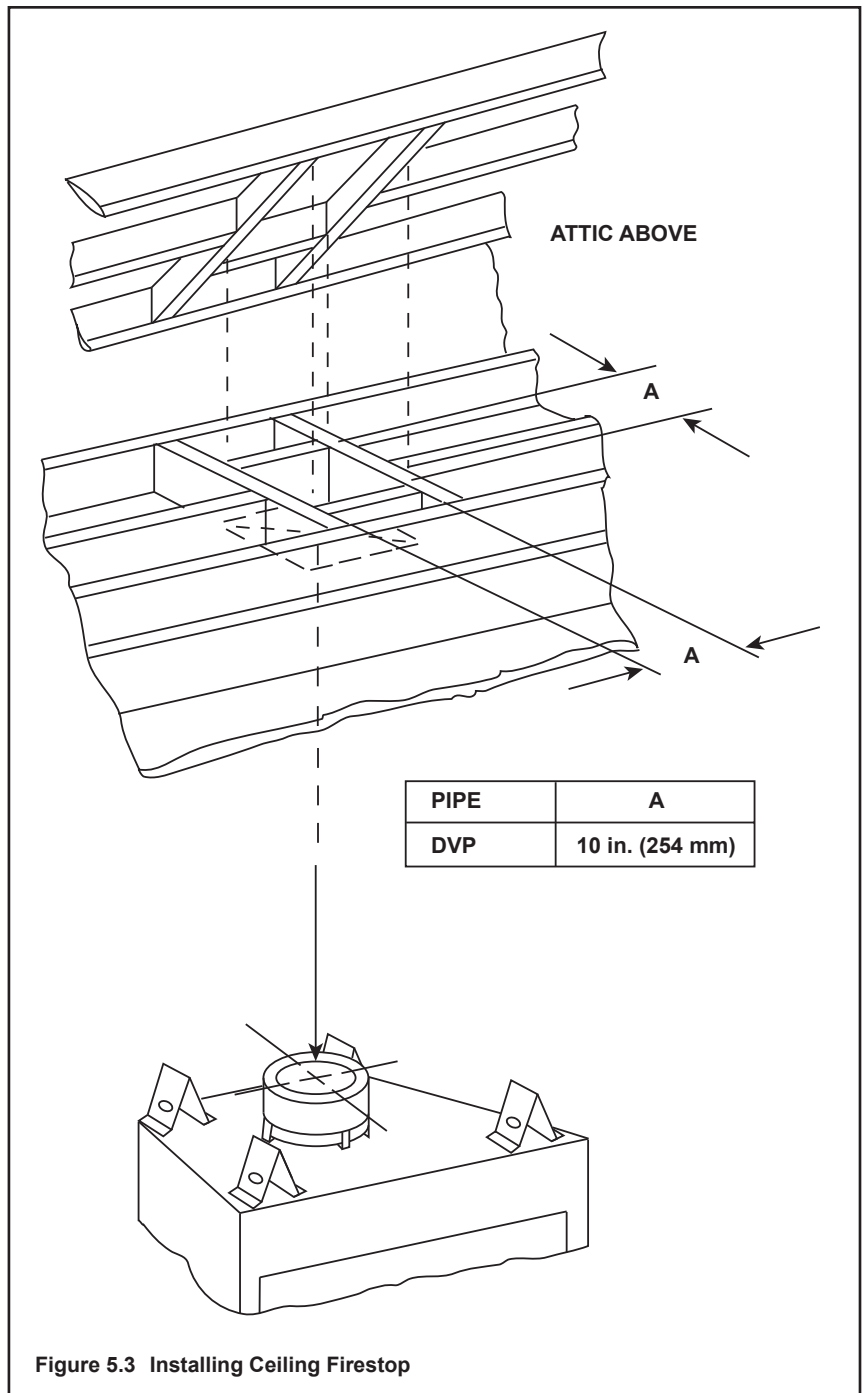

Figure 5.3 Installing Ceiling Firestop

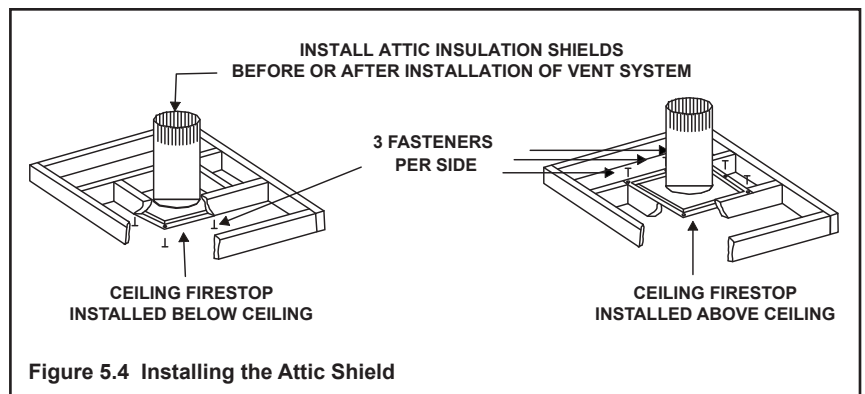
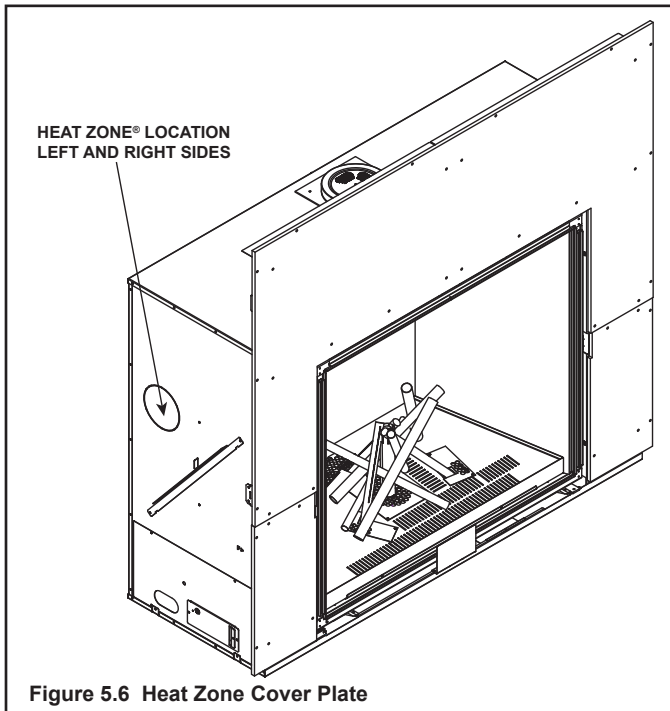

Figure 5.4 Installing the Attic Shield

## E. Installing the Optional Heat-Zone® Gas Kit

- Locate the Heat-Zone® ports on the left and right sides of the appliance. See Figure 5.6. Remove the knockouts from the appliance with a tin snips.
- Center the duct collar around the exposed hole and attach it to the appliance with 3 screws. Note: Do this BEFORE final positioning of the appliance.
- Determine the location for the air register/fan housing assembly.

Reference the Heat-Zone® Gas Kit instructions for the remaining installation steps.



# 6 Appliance Preparation

## A. Vent Collar Preparation

**CAUTION! Risk of Cuts, Abrasions or Flying Debris.** Wear protective gloves and safety glasses during installation. Sheet metal edges are sharp.

**NOTICE:** This appliance is top vented ONLY.

1. Remove shrink wrap from appliance. Figure 6.1 shows the shipping location of the seal cap and heat shields (Section 6), finishing templates (Section 10), and the glass refractory and media (Section 11).
2. Remove seal cap from top of appliance by removing one screw, which is included, to prevent construction material from getting into appliance. Remove seal cap when pipe installation phase begins. See Figure 6.2.
3. Ensure gasket seal is in place prior to installing vent pipe sections. Gasket is installed at the factory.



Figure 6.2 Seal Cap and Gasket Location



Figure 6.1 Shipping Location of Components

## B. Securing and Leveling the Appliance

**WARNING! Risk of Fire! Prevent contact with:**

- Sagging or loose insulation
- Insulation backing or plastic
- Framing and other combustible materials

Block openings into the chase to prevent entry of blown-in insulation. Make sure insulation and other materials are secured.

**DO NOT** notch the framing around the appliance standoffs.

Failure to maintain air space clearance may cause overheating and fire.

Nailing tabs are provided on the appliance and on the heat shields to secure the appliance to the framing members. See Figure 6.3 and Figure 6.5 for location of nailing tabs in shipping position.

- Bend out side nailing tabs 90 degrees. See Figure 6.4.
- Place the appliance into position.
- Keep side nailing tabs flush with the framing.
- Level the appliance from side to side and front to back.
- Shim the appliance as necessary. It is acceptable to use wood shims underneath the appliance.
- Position and install heat shields by securing two screws in each heat shield. See Figure 6.1 for shipping location of heat shields. The heat shield screws can be found pre-installed on the top of the appliance.
- Bend the top header heat shields upward to position them vertically and bend out the two nailing tabs on the top of each header heat shield. Secure to framing. See Figure 6.5.
- Secure the appliance to the framing by using nails or screws through the nailing tabs.
- Secure the appliance to the floor by inserting two screws through the pilot holes at the bottom of the appliance.

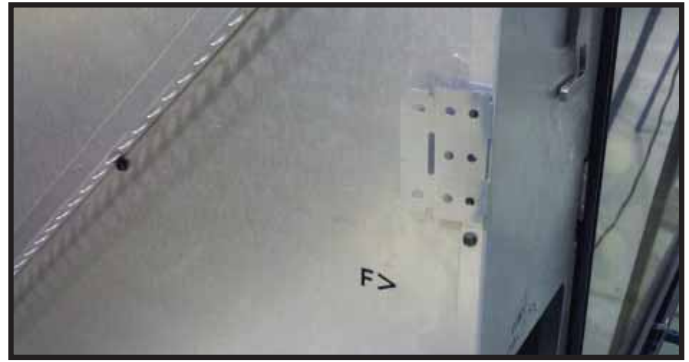

Figure 6.3 Side Nailing Tab in Shipping Position

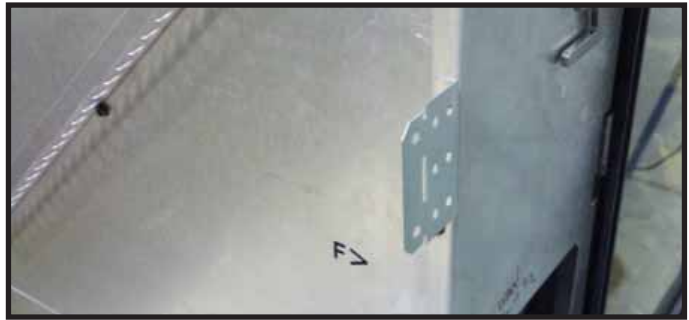

Figure 6.4 Side Nailing Tab Bent Out for Installation

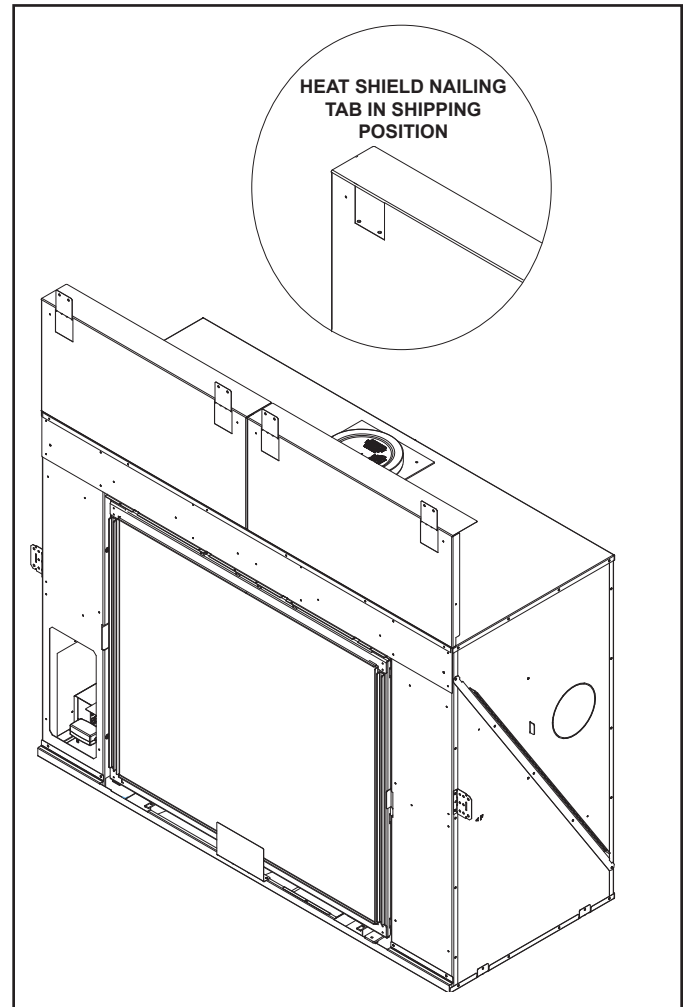

Figure 6.5. Heat Shields and Nailing Tabs in Installation Position

## C. Non-Combustible Material Installation

### **WARNING! Risk of Fire!**

- Follow these instructions exactly.
- Facing materials must be installed properly to prevent fire.
- No materials may be substituted without authorization by *Hearth & Home Technologies*.
- The finishing templates are shipped fastened to the top surround. Remove finishing templates prior to installing non-combustible board.
- The factory-supplied non-combustible material is shipped in front of the appliance in a large, protective cover. See Figure 6.1.
- Install lower left and right non-combustible legs and top non-combustible with screws supplied in the manual bag assembly. See Figure 6.6.
- Use fasteners from fastener packet (in manual bag) for screws that secure to the fireplace. See Figure 6.6.
- Use regular sheetrock screws or nails to secure the perimeter of the non-combustible facing materials to the wood framing. See Figure 6.6.
- Use a wet or dry towel or soft brush to remove dust or dirt from facing material.
- See Section 10 for finishing materials guidelines.

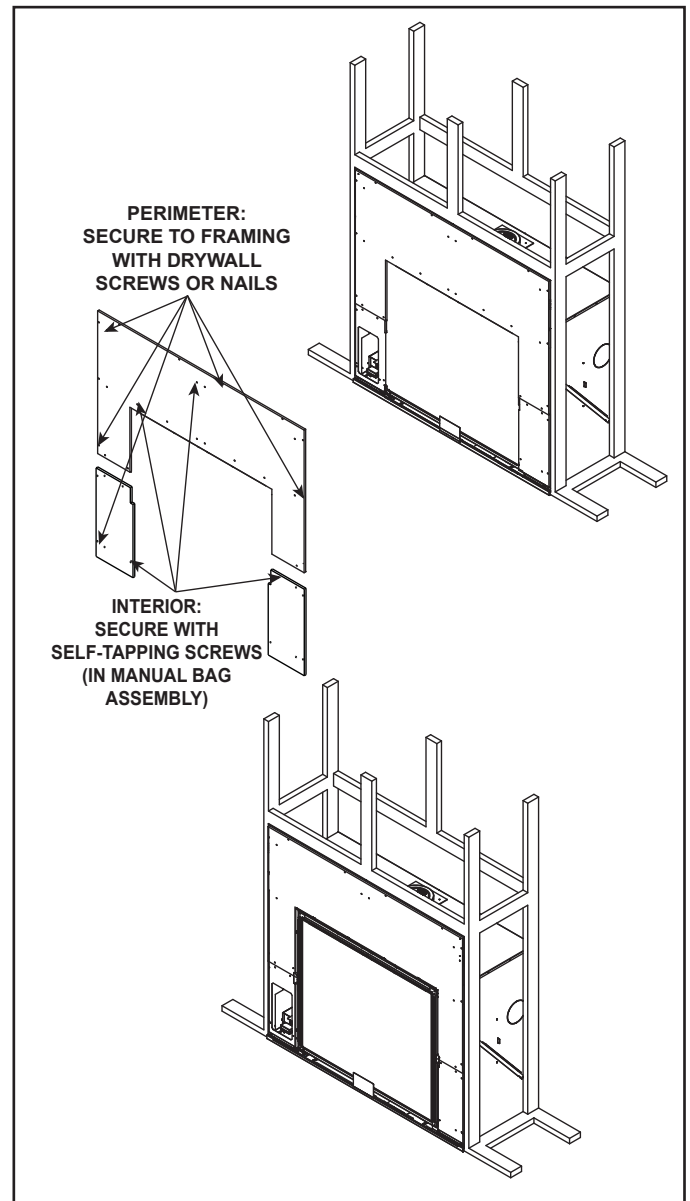

Figure 6.6 Installing Non-Combustible Facing Material

# 7 Venting and Chimneys

## A. Assemble Vent Sections

### Attach Vent to the Firebox Assembly

**Note:** The end of the pipe sections with the lanced tabs will face toward the appliance.

Attach the first pipe section to the starting collar:

- Lanced pipe end of the starting collar.
- Inner pipe over inner collar.
- Push the pipe section until all lanced tabs snap in place.
- Lightly tug on pipe to confirm it has locked.

### Required Commercial, Multi-family (Multi-level exceeding two stories), or High-Rise Applications

All outer pipe joints must be sealed with 100% silicone (300° F minimum continuous exposure rating), including the slip section that connects directly to the horizontal termination cap.

- Apply a bead of silicone sealant (300° F minimum continuous exposure rating) inside the female outer pipe joint prior to joining sections. See Figure 7.1.
- Only outer pipes need to be sealed. All unit collar, pipe, slip section, elbow and cap outer flues shall be sealed in this manner, unless otherwise stated.

**WARNING! Risk of Fire or Explosion! DO NOT break silicone seals on slip sections. Use care when removing termination cap from slip pipe. If slip section seals are broken during removal of the termination cap, vent may leak.**

### Assemble Pipe Sections

Per Figure 7.2:

- Start the inner pipe on the lanced end of section A into the flared end of section B.
- Start the outer pipe of section A over the outer pipe of section B.
- Once both vents sections are started, push firmly until all lanced tabs lock into place.
- Lightly tug on the pipe to confirm the tabs have locked.

It is acceptable to use screws no longer than 1/2 in. (13 mm) to hold outer pipe sections together. If predrilling holes, **DO NOT** penetrate inner pipe.

For 90° and 45° elbows that are changing the vent direction from horizontal to vertical, one screw minimum should be put in the outer flue at the horizontal elbow joint to prevent the elbow from rotating. Use screws no longer than 1/2 in. (13 mm). If predrilling screw holes, **DO NOT** penetrate inner pipe.



Figure 7.1 High Temperature Silicone Sealant

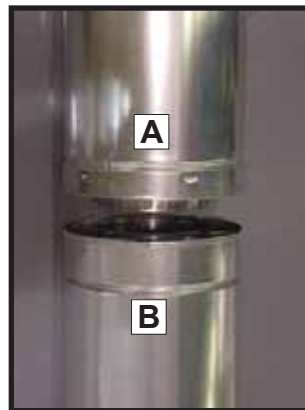

Figure 7.2



Figure 7.3

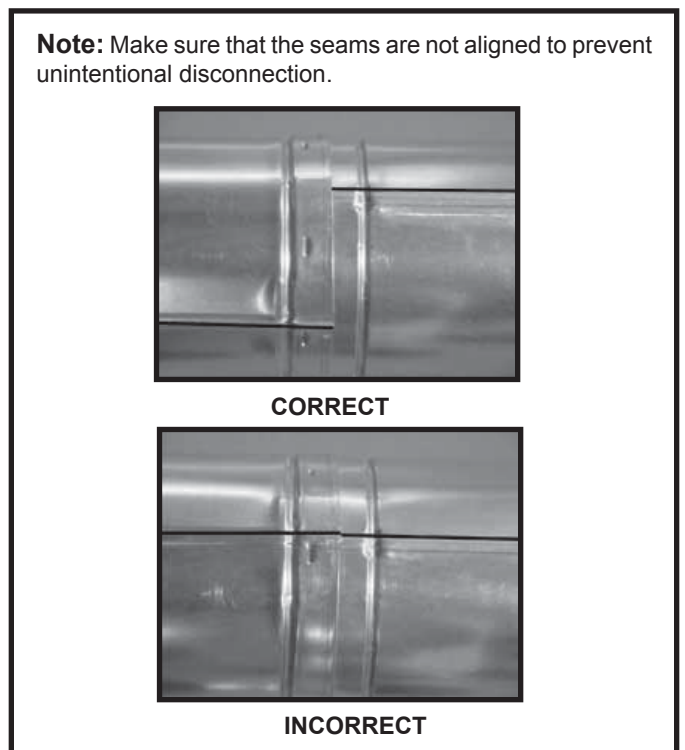

Figure 7.4 Seams

## B. Secure the Vent Sections

- Vertical runs originating off the top of the appliance, with no offsets, must be supported every 8 ft. (2.44 m) after the maximum allowed 25 ft. (7.62 m) of unsupported rise.
- Vertical runs originating off the rear of the appliance, or after any elbow, must be supported every 8 ft. (2.44 m).
- Horizontal runs must be supported every 5 feet (1.52 m).
- Vent supports or plumbers strap (spaced 120° apart) may be used to support vent sections. See Figures 7.5 and 7.6.
- Wall shield firestops may be used to provide horizontal support to vent sections.
- SLP ceiling firestops have tabs that may be used to provide vertical support.

**WARNING! Risk of Fire, Explosion or Asphyxiation!** Improper support may allow vent to sag and separate. Use vent run supports and connect vent sections per installation instructions. **DO NOT** allow vent to sag below connection point to appliance.

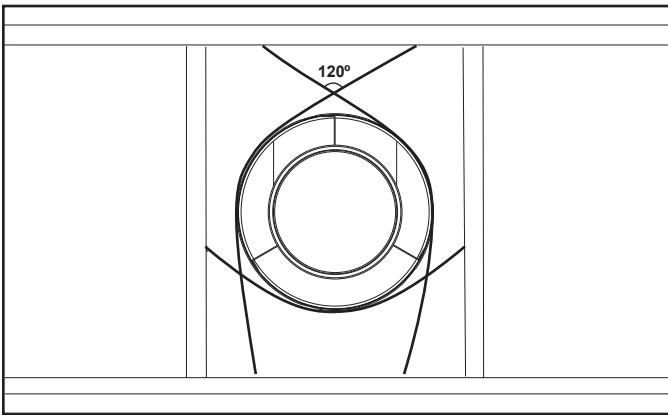

Figure 7.5 Securing Vertical Pipe Sections

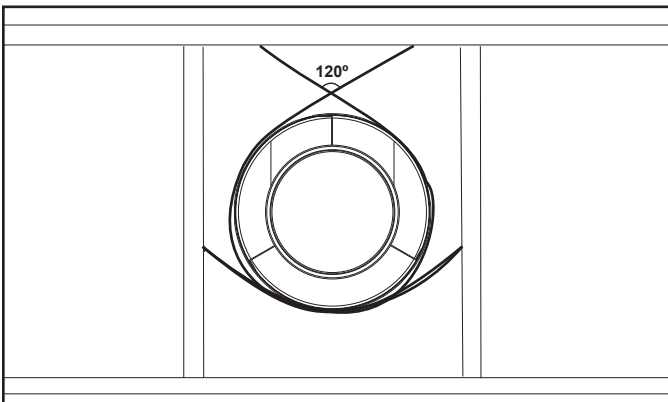

Figure 7.6 Securing Horizontal Pipe Sections

## C. Disassemble Vent Sections

- Rotate either section (see Figure 7.7) so the seams on both pipe sections are aligned as shown in Figure 7.8.
- Pull carefully to separate the pieces of pipe.

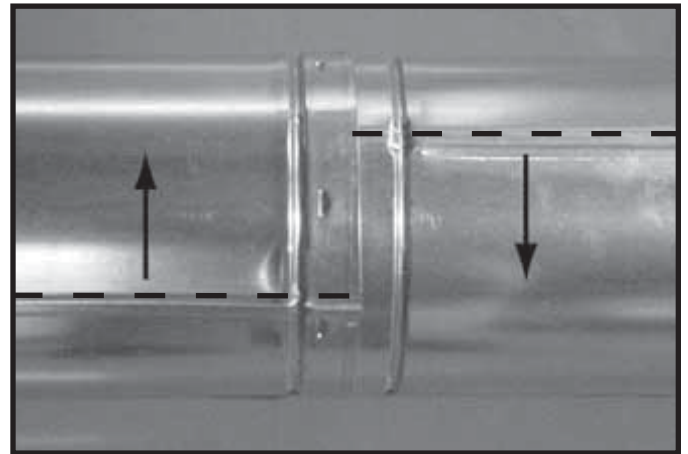

Figure 7.7 Rotate Seams for Disassembly

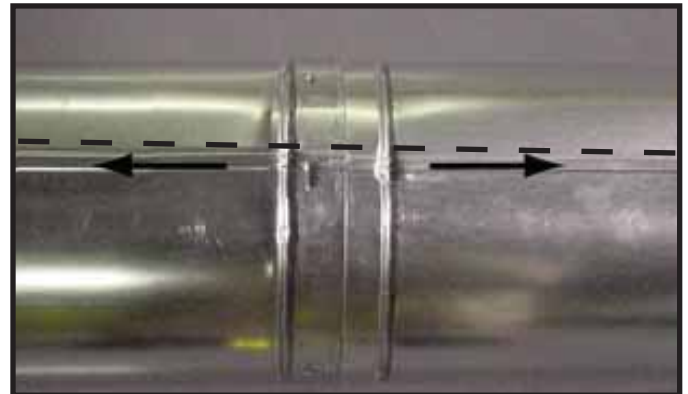
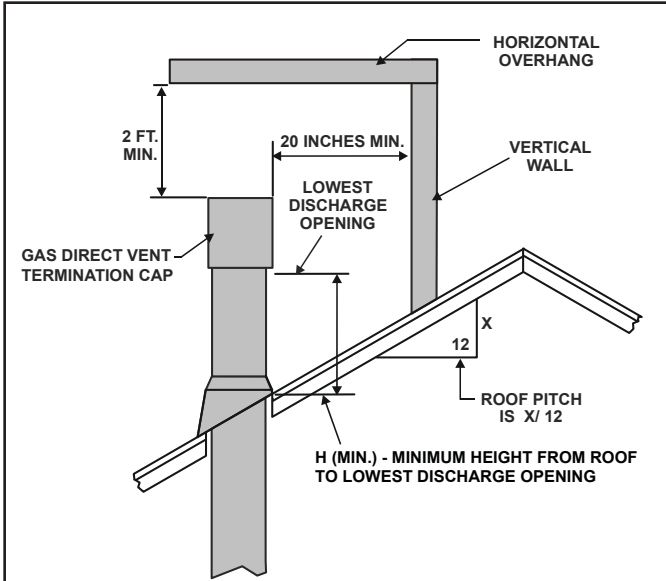

Figure 7.8 Align and Disassemble Vent Sections

## D. Vertical Termination Requirements

### Install Metal Roof Flashing

- See minimum vent heights for various pitched roofs (Figure 7.9) to determine the length of pipe to extend through the roof.
- Slide the roof flashing over the pipe sections extending through the roof as shown in Figure 7.10.



<u>Roof Pitch</u>	<u>H (Min.) Ft.</u>
Flat to 6/12.....	1.0*
Over 6/12 to 7/12.....	1.25*
Over 7/12 to 8/12.....	1.5*
Over 8/12 to 9/12.....	2.0*
Over 9/12 to 10/12.....	2.5*
Over 10/12 to 11/12.....	3.25
Over 11/12 to 12/12.....	4.0
Over 12/12 to 14/12.....	5.0
Over 14/12 to 16/12.....	6.0
Over 16/12 to 18/12.....	7.0
Over 18/12 to 20/12.....	7.5
Over 20/12 to 21/12.....	8.0

\* 3 foot minimum in snow regions

**Figure 7.9 Minimum Height From Roof To Lowest Discharge Opening**

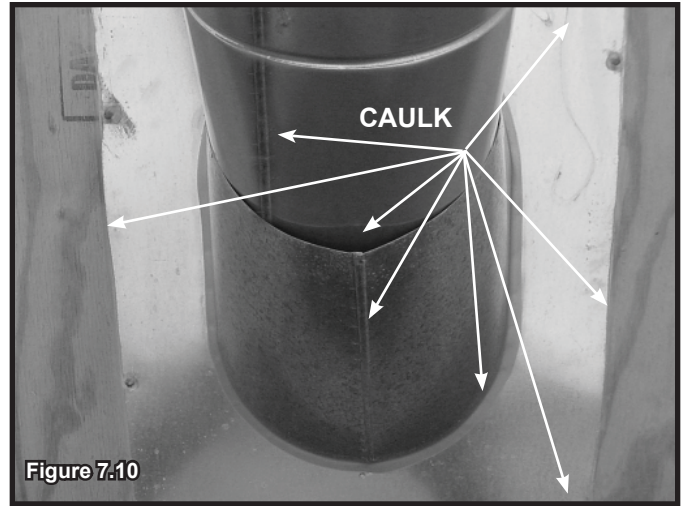

**Figure 7.10**

### Assemble and Install Storm Collar

**CAUTION! Risk of Cuts, Abrasions or Flying Debris.** Wear protective gloves and safety glasses during installation. Sheet metal edges are sharp.

- Slide the storm collar onto the exposed pipe section and align brackets.
- Insert a bolt (provided) through the brackets and install nut. Do not completely tighten.



**Figure 7.11 insert Bolt into Brackets**

- Slide the assembled storm collar down the pipe section until it rests on the roof flashing. See Figure 7.11.
- Tighten nut and make sure the collar is tight against the pipe section.
- Caulk around the top of the storm collar. See Figure 7.12.

**NOTICE:** Failure to properly caulk the roof flashing and pipe seams may permit entry of water.

- Caulk the gap between the roof flashing and the outside diameter of the pipe.
- Caulk the perimeter of the flashing where it contacts the roof surface. See Figure 7.10.
- Caulk the overlap seam of any exposed pipe sections that are located above the roof line.



## Install Vertical Termination Cap

- Attach the vertical termination cap by sliding the inner collar of the cap into the inner flue of the pipe section while placing the outer collar of the cap over the outer flue of the pipe section.
- Secure the cap by driving three self-tapping screws (supplied) through the pilot holes in the outer collar of the cap into the outer flue of the pipe. See Figure 7.12.



## E. Horizontal Termination Requirements

### Heat Shield Requirements for Horizontal Termination

**WARNING! Risk of Fire!** To prevent overheating and fire, heat shields must extend through the entire wall thickness.

- **DO NOT** remove the heat shields attached to the wall shield firestop and the horizontal termination cap (shown in Figure 7.13).
- Heat shields must overlap 1-1/2 in. (38 mm) minimum.

There are two sections of the heat shield. One section is factory-attached to the wall shield firestop. The other section is factory-attached to the cap. See Figure 7.13.

If the wall thickness does not allow the required 1-1/2 in. (38 mm) heat shield overlap when installed, an extended heat shield must be used.

- If the wall thickness is less than 4 in./102 mm (DVP) or 4-3/8 in./ 111 mm (SLP), the heat shields on the cap and wall shield firestop must be trimmed. A minimum 1-1/2 in. (38 mm) overlap **MUST** be maintained.
- Use an extended heat shield if the finished wall thickness is greater than 7-1/4 in. (184 mm).
- The extended heat shield may need to be cut to length maintaining sufficient length for a 1-1/2 in. (38 mm) overlap between heat shields.
- Attach the extended heat shield to either of the existing heat shields using the screws supplied with the extended heat shield. Refer to vent components diagrams in the back of this manual.
- Rest the small leg on the extended heat shield on top of the pipe section to properly space it from the pipe section.

**Important Notice:** Heat shields may not be field constructed.

## Install Horizontal Termination Cap

**WARNING! Risk of Fire!** The telescoping flue section of the termination cap **MUST** be used when connecting vent.

- 1-1/2 (38 mm) minimum overlap of flue telescoping section is required.

Failure to maintain overlap may cause overheating and fire.

- Vent termination must not be recessed in the wall. Siding may be brought to the edge of the cap base.
- Flash and seal as appropriate for siding material at outside edges of cap.
- When installing a horizontal termination cap, follow the cap location guidelines as prescribed by current **ANSI Z223.1** and **CAN/CGA-B149** installation codes and refer to Section 4 of this manual.

**CAUTION! Risk of Burns!** Local codes may require installation of a cap shield to prevent anything or anyone from touching the hot cap.

**NOTICE:** For certain exposures which require superior resistance to wind-driven rain penetration, a flashing kit and HRC caps are available. When penetrating a brick wall, a brick extension kit is available for framing the brick.

**Note:** When using termination caps with factory-supplied heat shield attached, no additional wall shield firestop is required on the exterior side of a combustible wall.

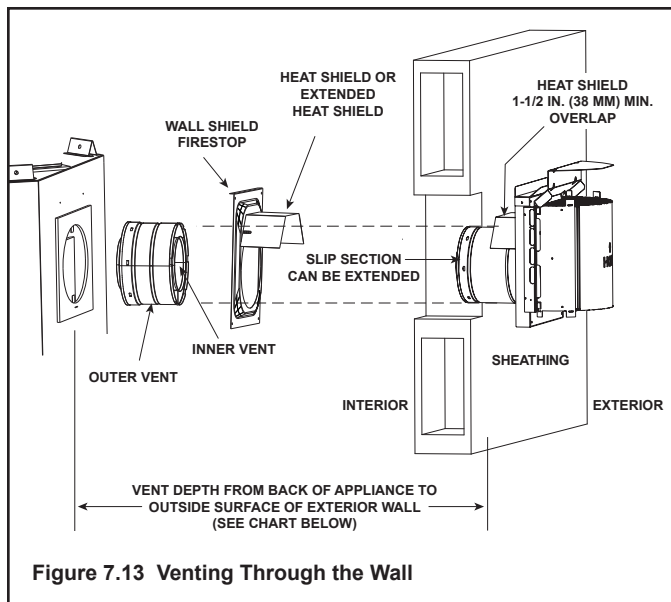

# 8 Electrical Information

## A. General Information

**WARNING! Risk of Shock or Explosion! DO NOT** wire 110-120 VAC to the valve or to the appliance wall switch. Incorrect wiring will damage controls.

**NOTICE:** This appliance must be electrically wired and grounded in accordance with local codes or, in the absence of local codes, with **National Electric Code ANSI/NFPA 70-latest edition or the Canadian Electric Code CSA C22.1.**

- Wire the appliance junction box to unswitched 110-120 VAC. This is required for proper operation of the appliance.
- A 110-120 VAC circuit for this product must be protected with ground-fault circuit-interrupter protection, in compliance with the applicable electrical codes, when it is installed in locations such as in bathrooms or near sinks.
- Low voltage and 110-120 VAC voltage cannot be shared within the same wall box.

## Junction Box Installation

The electrical junction box can be accessed three ways during installation:

1. Through the side electrical access:
  - Remove two screws to release junction box bracket from the access plate. See Figure 3.2 and Figure 8.2.
2. Through the front left column (behind the factory-installed non-combustible board):
  - From inside remove one screw that secures junction box to junction box bracket. See Figure 8.1 and Figure 8.2.
3. Through the firebox:
  - From inside remove one screw that secures junction box to junction box bracket. See Figure 8.1 and Figure 8.2.
  - Pull the electrical wires from outside the appliance through the opening into the valve compartment and secure wires with a Romex connector. See Figure 8.2.
  - Make all necessary wire connections to the junction box/receptacle and reattach the junction box/receptacle to the outer shell.

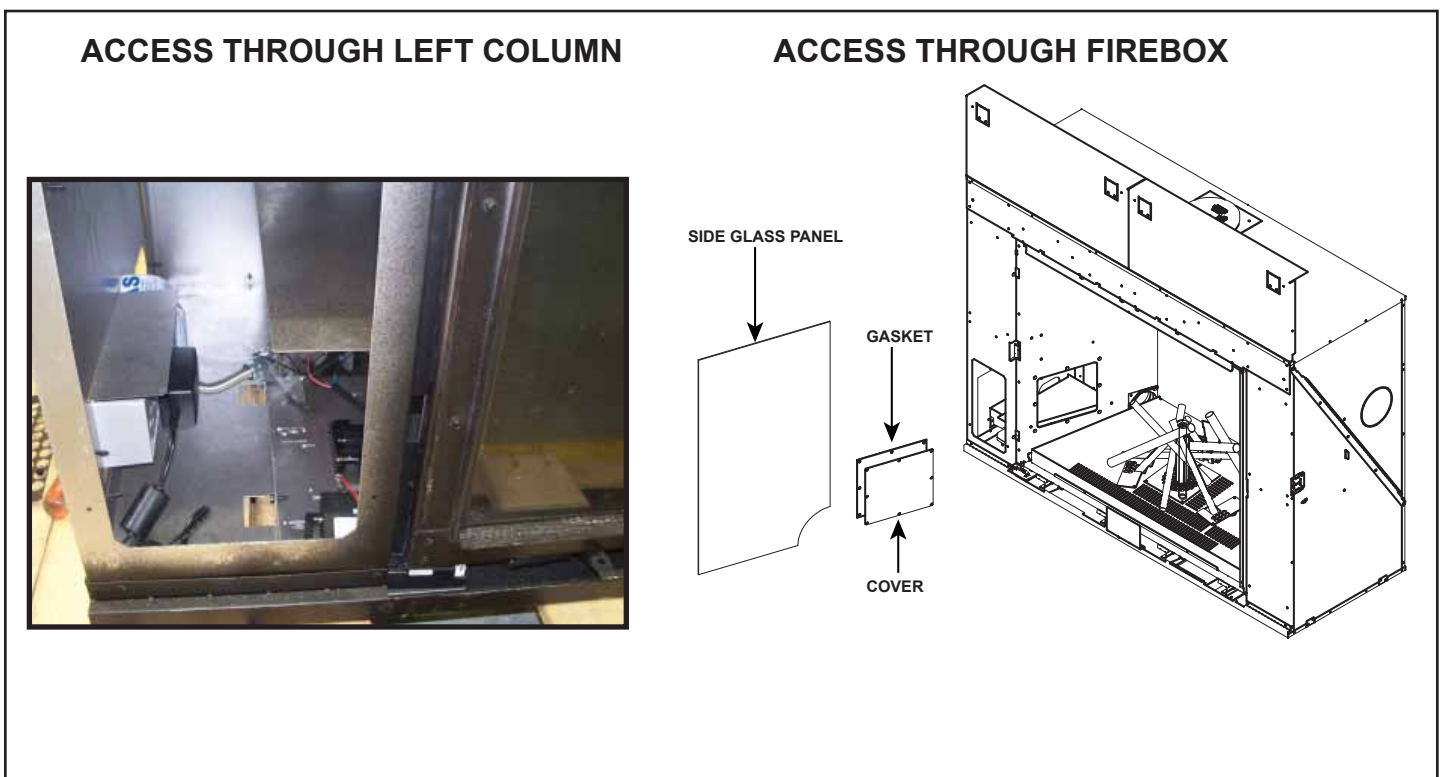

Figure 8.1 Junction Box Access

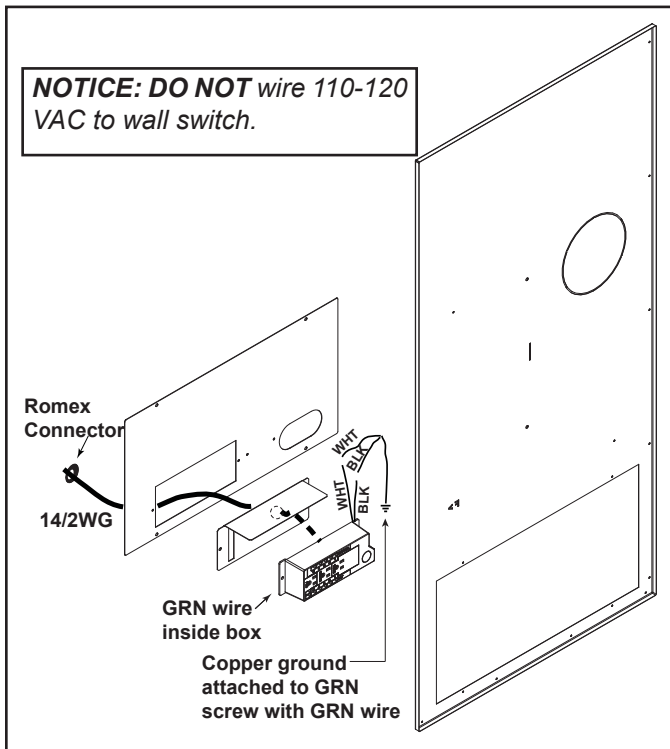

Figure 8.2 Junction Box Detail

## Accessories Requirements

- This appliance may be used with a wall switch, wall mounted thermostat and/or a remote control.

Wiring for optional Hearth & Home Technologies approved accessories should be done now to avoid reconstruction. Follow instructions that come with those accessories.

- Hearth & Home Technologies recommends that IntelliFire Plus™ wireless controls be used for their features and functionality with the IntelliFire Plus™ ignition system.

## Electrical Service and Repair

**WARNING! Risk of Shock!** Label all wires prior to disconnection when servicing controls. Wiring errors can cause improper and dangerous operation. Verify proper operation after servicing.

**WARNING! Risk of Shock!** Replace damaged wire with type 105° C rated wire. Wire must have high temperature insulation.

## B. Wiring Requirements

### IntelliFire Plus Ignition System Wiring

- Wire the appliance junction box to 110-120 VAC for proper operation of the appliance.

**WARNING! Risk of Shock or Explosion! DO NOT wire IPI controlled appliance junction box to a switched circuit. Incorrect wiring will override IPI safety lockout.**

- Refer to Figure 8.3, IPI Wiring Diagram.
- This appliance is equipped with an IntelliFire Plus™ control valve which operates on a 6 volt/1.5 AMP system.
- Plug the 6 volt transformer plug into the appliance junction box to supply power to the unit OR install 4 AA cell batteries (not included) into the battery pack before use.

**NOTICE:** Batteries should only be used as a power source in the event of an emergency power outage. Batteries should not be used as a primary long-term power source. Battery polarity must be correct when installing batteries. When using batteries as a power source, the 6-volt transformer must be unplugged from the receptacle.

Do not store batteries in the battery pack when the appliance is powered by the 6 volt transformer connected to permanent electrical service.

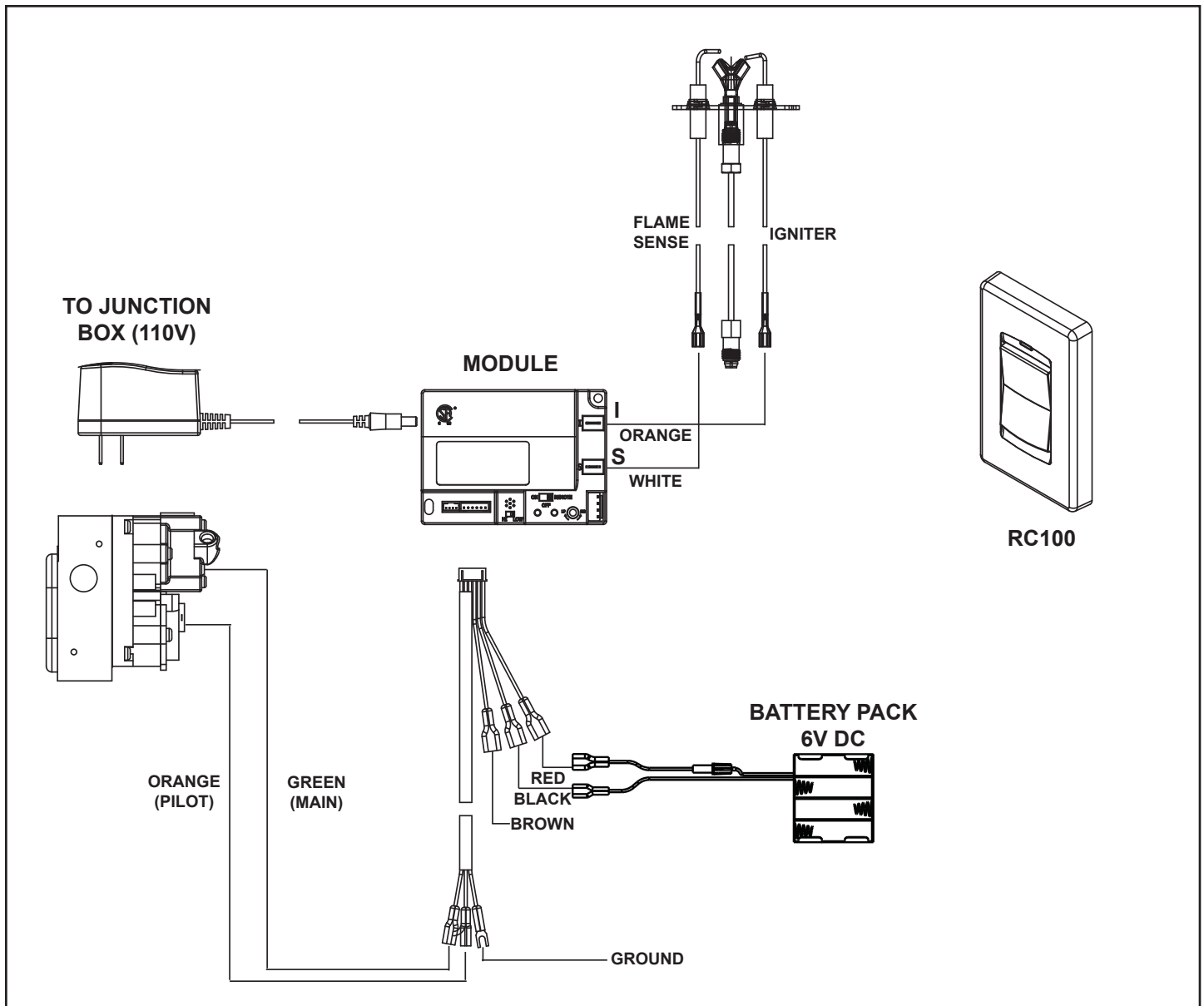

Figure 8.3 IntelliFire Pilot Ignition (IPI) Wiring Diagram

# 9 Gas Information

## A. Fuel Conversion

The LUX36 and LUX42 models are made for use with Natural Gas only. Conversion is not allowed.

## B. Gas Pressure

- Optimum appliance performance requires proper input pressures.
- Gas line sizing requirements will be determined in ANSI Z223.1 National Fuel Gas Code in the USA and CAN/CGA B149 in Canada.
- Pressure requirements are:

Gas Pressure	Natural Gas
Minimum inlet pressure	5.0 in. w.c.
Maximum inlet pressure	10.0 in. w.c.
Manifold pressure	3.5 in. w.c.

**WARNING! Risk of Fire or Explosion!** High pressure will damage valve. Low pressure may cause explosion.

- Verify inlet pressures. Verify minimum pressures when other household gas appliances are operating.
- Install regulator upstream of valve if line pressure is greater than 1/2 psig.

**⚠ WARNING**



Fire Risk.  
Explosion Hazard.  
High pressure will damage valve.

- Disconnect gas supply piping BEFORE pressure testing gas line at test pressures above 1/2 psig.
- Close the manual shutoff valve BEFORE pressure testing gas line at test pressures equal to or less than 1/2 psig.

**Note:** Have the gas supply line installed in accordance with local codes, if any. If not, follow ANSI 223.1. Installation should be done by a qualified installer approved and/or licensed as required by the locality. (In the Commonwealth of Massachusetts installation must be performed by a licensed plumber or gas fitter).

**Note:** A listed (and Commonwealth of Massachusetts approved) 1/2 in. (13 mm) T-handle manual shut-off valve and flexible gas connector are connected to the 1/2 in. (13 mm) control valve inlet.

- **If substituting for these components, please consult local codes for compliance.**

## C. Gas Connection

- Refer to Reference Section 3 for location of gas line access in appliance.
- Gas line may be run through knockout(s) provided.
- The gap between supply piping and gas access hole may be caulked with caulk with a minimum of 300°F continuous exposure rating or stuffed with non-combustible, unfaced insulation to prevent cold air infiltration.
- Ensure that gas line does not come in contact with outer wrap of the appliance. Follow local codes.
- Pipe incoming gas line into valve compartment.
- Connect incoming gas line to the 1/2 in. (13 mm) connection on manual shutoff valve.

**WARNING! Risk of Fire or Explosion!** Support control when attaching pipe to prevent bending gas line.

- A small amount of air will be in the gas supply lines.

**WARNING! Risk of Fire or Explosion!** Gas build-up during line purge could ignite.

- Purge should be performed by qualified service technician.
- Ensure adequate ventilation.
- Ensure there are no ignition sources such as sparks or open flames.

Light the appliance. It will take a short time for air to purge from lines. When purging is complete the appliance will light and operate normally.

**WARNING! Risk of Fire, Explosion or Asphyxiation!** Check all fittings and connections with a non-corrosive commercially available leak-check solution. **DO NOT** use open flame. Fittings and connections could have loosened during shipping and handling.

**WARNING! Risk of Fire! DO NOT** change valve settings. This valve has been preset at the factory.

## D. High Altitude Installations

**NOTICE:** If the heating value of the gas has been reduced, these rules do not apply. Check with your local gas utility or authorities having jurisdiction.

When installing above 2000 feet elevation:

- In the USA: Reduce burner orifice 4% for each 1000 feet above 2000 feet.
- In CANADA: Reduce burner orifice 10% for elevations between 2000 feet and 4500 feet. Above 4500 feet, consult local gas utility.

## E. Air Shutter Setting

Air shutter settings should be adjusted by a qualified service technician at the time of installation. The air shutter is set at the factory for minimum vertical vent run. Air shutter may need to be adjusted for longer vertical vent runs. See Figure 9.1.

- Loosen the screw on the burner assembly.
- Rotate the air shutter to the correct setting.
- Push the air handle in to close the air shutter.
- Tighten the screw.

**NOTICE:** If sooting occurs, provide more air by opening the air shutter.

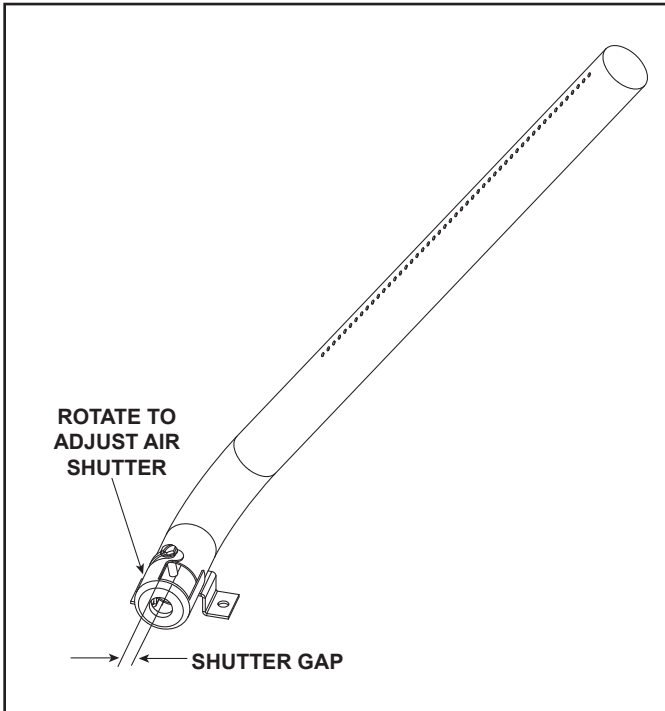

Figure 9.1 Air Shutter

### Air Shutter Settings

LUX36 (NG)	
Left Burner Tube	1/8 in.
Right Burner Tube	1/8 in.
Rear Burner Tube	1/4 in.
Center Burner Tube	1/4 in.
LUX42 (NG)	
Left Burner Tube	1/8 in.
Right Burner Tube	1/8 in.
Rear Burner Tube	1/4 in.
Center Burner Tube	1/4 in.

# 10 Finishing

## A. Finishing Templates

Two side finishing templates and one top finishing template are supplied with the appliance. They are fastened to the shipping pallet. The templates are used with the LMOD-36 and LMOD-42 decorative fronts when finishing materials such as marble, tile or stone exceeding one inch thick.

**Note:** If the desired front is an FS-36 or FS-42, do not use the supplied templates. Refer to Section 13.E for template and finishing information.

**INSIDE FIT Method:** The finishing template pieces are required for installations that require more than one inch thick finishing materials to be installed over the face of the factory-supplied 1/2 inch non-combustible board. Refer to section 13.E for more information.

**OVERLAP Method:** The supplied templates are not required for finishing materials less than one inch thick. The required decorative front will overlap finish materials less than one inch thick. Refer to section 13.E for more information.

### Template installation instruction

1. Refer to Section 10.E for door clearance information.
2. If applicable, bend the left and right side templates for the appropriate door type using Figure 10.1 as a reference.
3. Locate the four threaded inserts on the inside edge of the fireplace and secure the side templates with the Phillips screws provided. See Figure 10.2.
4. Bend the top template as shown in Figure 10.3 and secure with the two screws provided.
5. Remove all template components once finishing materials are secured.

**Note:** A thin layer of mortar may be applied over the visible non-combustible board between finishing material and the fireplace opening.

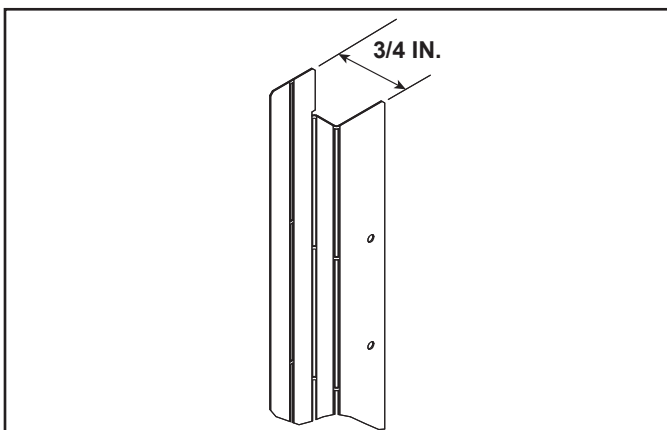

Figure 10.1 Side Finishing Template Bend - LMOD Series Doors

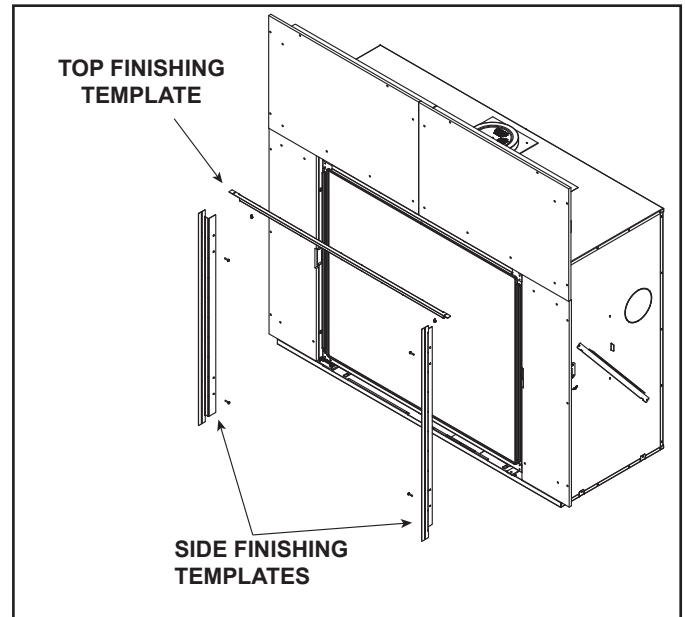

Figure 10.2 Top and Side Finishing Template Locations

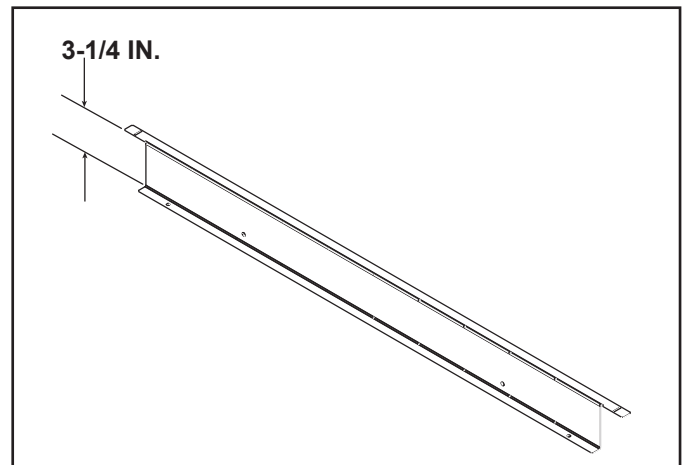

Figure 10.3 Top Finishing Template Bend - LMOD Series Doors



Figure 10.4 Top/Side Finishing Templates Installed



## B. Facing Material

- Metal front faces may be covered with non-combustible materials only.
- Facing and/or finishing materials must not interfere with air flow through louvers, operation of louvers or doors, or access for service.
- Facing and/or finishing materials must never overhang into the glass opening.
- Observe all clearances when applying combustible materials.
- Seal joints between the finished wall and appliance top and sides using a 300°F minimum sealant. Refer to Figure 10.5.

**WARNING! Risk of Fire! DO NOT** apply combustible materials beyond the minimum clearances. Comply with all minimum clearances to combustibles as specified in this manual. Overlapping materials could ignite and will interfere with proper operation of doors and louvers.

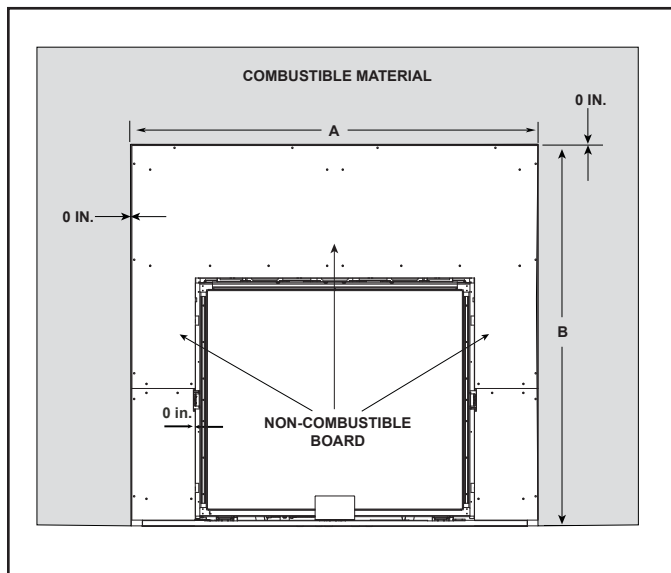

Figure 10.5 Non-combustible Facing Diagram

MODEL	A		B	
	in.	mm	in.	mm
LUX36	61	1549	57-5/8	1464
LUX42	67	1702	62-5/8	1591

## C. Splatter Guard

The splatter guard is a piece of corrugated material used to protect the appliance during the installation process before finishing work on the whole hearth is complete. Splatter guards may be factory installed or accompany the door of the appliance, depending on the fireplace model. Splatter guards must be removed before appliance is fired.

**WARNING! Risk of Fire! Close the ball valve before installing the splatter guard to prevent accidental lighting. Remove the splatter guard before lighting the appliance.**

1. Fold top flap along scored lines.
2. Slide side tabs into slots by sides of glass.



Figure 10.6

## D. Mantel and Wall Projections

**WARNING! Risk of Fire!** Comply with all minimum clearances as specified. Framing closer than the minimums listed must be constructed entirely of non-combustible materials (i.e., steel studs, concrete board, etc.).

When installing a mantel, provisions must be made in order to secure the mantel to the adjacent framing materials. For example, lintel brackets or lag bolts may be considered for this purpose.

### Combustible Mantel Legs or Wall Projections

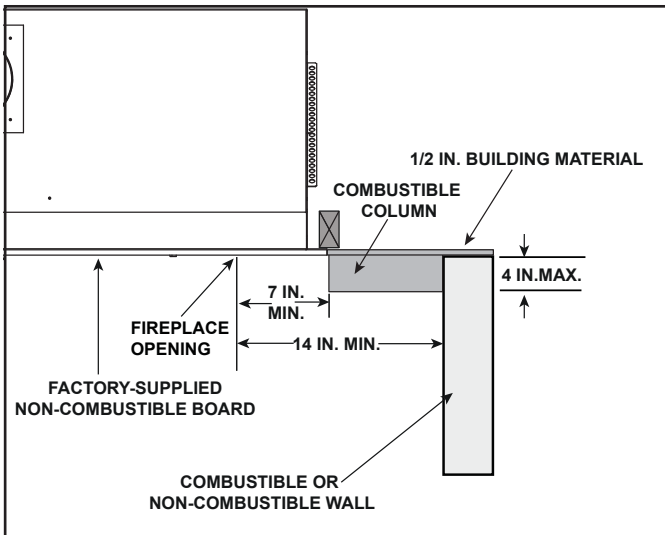

Figure 10.7 Combustible Mantel Leg and Wall Projections

### Non-Combustible Mantel Legs or Wall Projections

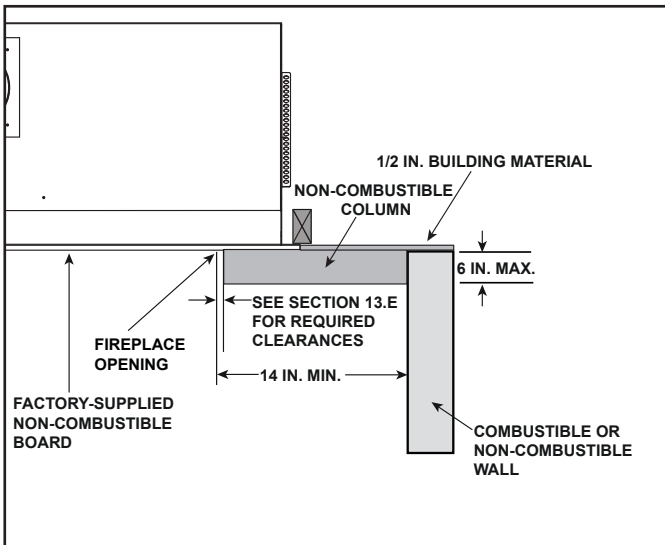
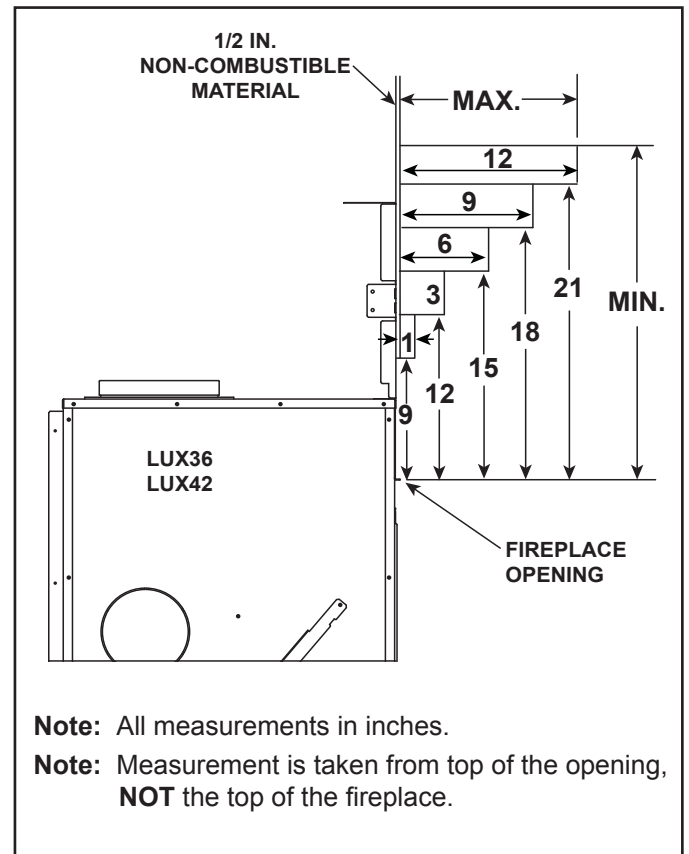

Figure 10.8 Non-Combustible Mantel Leg and Wall Projections

### Combustible Mantel Projections



**Note:** All measurements in inches.

**Note:** Measurement is taken from top of the opening, NOT the top of the fireplace.

Figure 10.9 Combustible Mantel Allowance

### Non-Combustible Mantel Projections

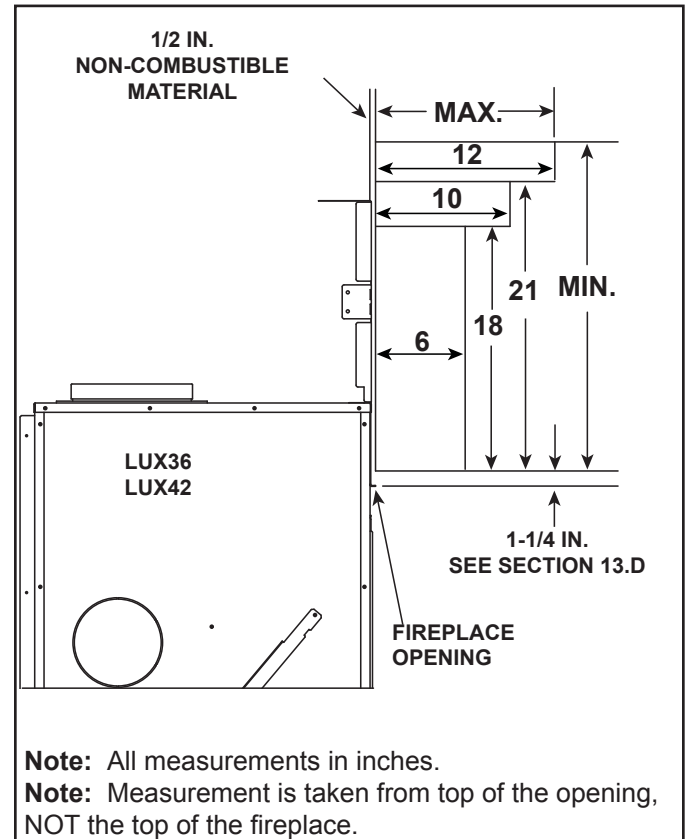

**Note:** All measurements in inches.

**Note:** Measurement is taken from top of the opening, NOT the top of the fireplace.

Figure 10.10 Non-Combustible Mantel Allowance

## Non-Combustible Zone

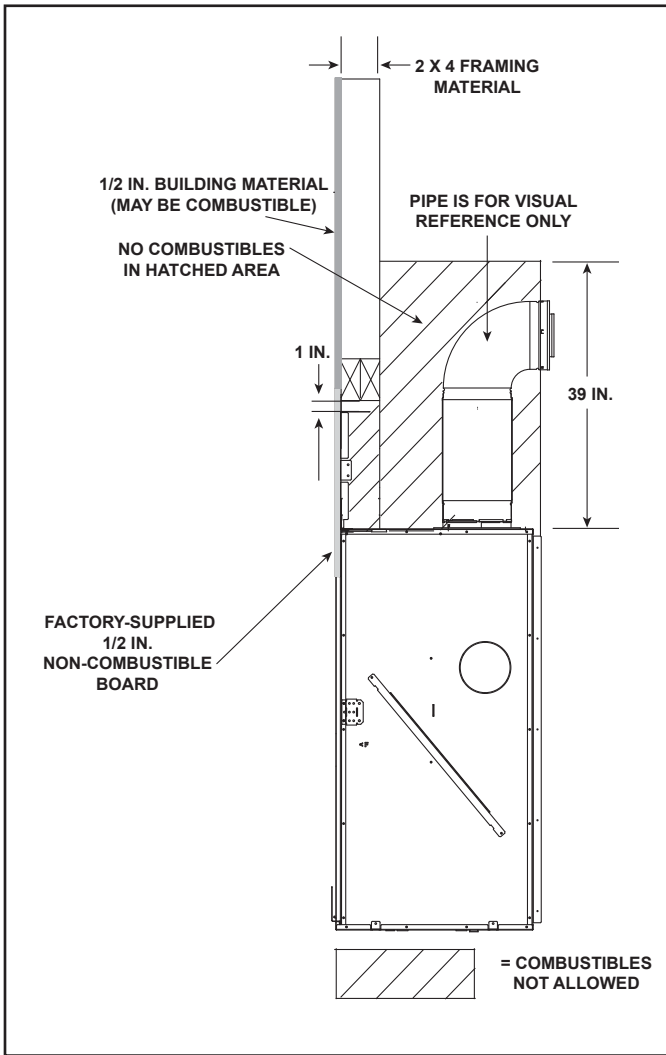

→ Figure 10.11 Non-Combustible Zone

## E. Doors

A door (decorative front) is required for this appliance. Only doors certified for use with this appliance model may be used. The following doors are approved:

- FS-36-XX
- FS-42-XX
- LMOD-36XX
- LMOD-42XX

(X = color choice)

Door finishing templates designed for use with the LMOD Series doors are included with this appliance. Door finishing templates for the FS Series doors may be ordered separately from Hearth & Home Technologies dealers. See below.

DOOR	TOP PART#	QTY	SIDE PART#	QTY
FS-36	2280-331	1	2280-330	2
FS-42	2281-331	1	2281-330	2

The doors approved for use with this appliance have been designed to be installed by two methods: Overlap Fit or Inside Fit. Before beginning the installation, it is important to determine which method will be used.

**Overlap Fit Doors:** These doors have been designed to be installed over finishing material that is less than one inch thick.

**Inside Fit Doors:** These doors may be recessed into non-combustible finishing material up to 4 inches thick.

**NOTICE:** Proper clearances from the fireplace opening to finishing material thicker than 1 inch **MUST** be maintained when installing appliance in an inside fit application. See Figure 10.12.

**NOTE:** Finishing templates are included with this product. See Section 10.A.

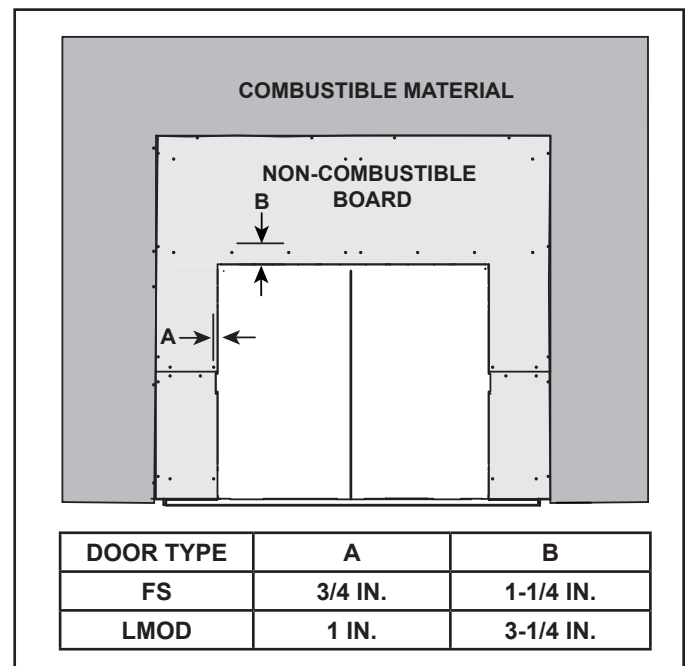

Figure 10.12 Required Clearance for Inside Fit Doors

# 11 Appliance Setup

## A. Fixed Glass Assembly

**WARNING! Risk of Asphyxiation!** Handle fixed glass assembly with care. Inspect the gasket to ensure it is undamaged and inspect the glass for cracks, chips or scratches.

- **DO NOT** strike, slam or scratch glass.
- **DO NOT** operate fireplace with glass removed, cracked, broken or scratched.
- Replace as a complete assembly.

**WARNING! Risk of Injury!** Glass assembly installation and removal must be performed by a qualified service technician. See chart below for glass assembly weights.

**LUX42 MODELS:** It is recommended that Glass installation and removal be performed by two qualified service technicians.

Glass Weights	
LUX36	LUX42
32 lbs	41 lbs

**CAUTION! Risk of Cuts or Abrasions.** Wear protective gloves and safety glasses during installation. Sheet metal edges are sharp.

### Removing Fixed Glass Assembly

This fixed glass assembly is held in place by side and bottom glass clips and top retaining rail. To remove clips, engage the spring clips with the tool and pull tool out slightly. Rotate wrist left and right to disengage clip. See Figure 11.1 to understand function of this tool.

1. Glass clip removal/installation tool is fastened to the lower right corner of the fireplace. Remove tool by removing one screw. See Figure 11.1. If glass clip removal tool becomes misplaced, a cotter pin removal tool may be used. Replace glass clip removal/installation tool in same place with the one screw after use.



Figure 11.1. Glass Clip Tool



Figure 11.2 Glass Clip Tool Location

2. To disengage bottom glass clips, position the glass clip removal/installation tool parallel to the floor and insert it about two inches into the gap between the glass frame and the front bottom fireplace lip. Insert the tool on the lower left side of the glass clip and move to the right to engage the clip. Lift up to about 45 degrees and pull the tool out slightly. Then push downward to disengage the bottom spring clip. Repeat for the other two or three bottom spring clips. See Figure 11.2.



Figure 11.3 Inserting Glass Clip Tool

3. Disengage the left and right glass clips one at a time using the glass clip removal/installation tool. Insert tool from the top side of the side glass clip. Pull the glass tool out slightly to disengage the side clip.
4. Grasp the left and right sides of the glass assembly and carefully pull outward to remove the bottom from the three support tabs on the bottom glass clips. Lower the glass to remove it from the top retainer rail.

**CAUTION! Risk of Injury! DO NOT** put fingers under glass frame. Fingers may get pinched by glass frame during removal.

## Replacing Fixed Glass Assembly

This fixed glass assembly is held in place by three lower glass clips, two side clips and one top retaining rail. To remove clips, engage the spring clips with the tool and pull tool out slightly. Rotate wrist left and right to disengage clip. The glass clip tool is shown in Figure 11.1.

1. Tool is fastened to the lower right corner of the fire-place. Remove tool by removing one screw. If glass clip removal tool becomes misplaced, a cotter pin removal tool may be used.
2. Position the fixed glass assembly so that it is about eight inches from the face of the appliance. See Figure 11.4.



Figure 11.4. Position Glass

3. Center the fixed glass assembly from left to right inside the top of the appliance opening. Align the notch at the top center of the glass frame assembly with the notch on the top retaining rail. The glass frame has tabs on the bottom that coincide with the bottom glass clip location. The LUX36 has three tabs and the LUX42 has four tabs. If the glass is not centered, it can not be installed properly. See Figure 11.5.
4. Install fixed glass assembly by lifting it up and sliding it into the top retaining rail. Grasp the fixed glass assembly on the sides.

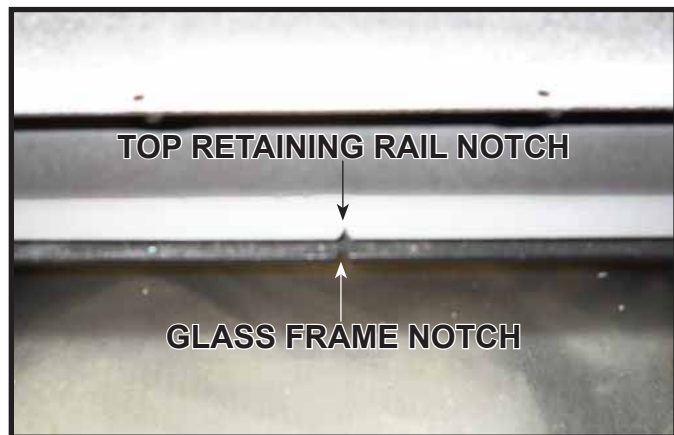

Figure 11.5. Align Notches

**CAUTION! Risk of Injury! DO NOT** put fingers under glass frame. Fingers may get pinched by glass frame during installation.

Once the glass is installed fully into the top retaining rail, push in the bottom so that the glass assembly rests on the three support tabs on the glass clip. See Figure 11.6.

5. Ensure that the fixed glass assembly is situated tight against the firebox face. Engage the left and right glass clips using the glass clip tool. See Figure 11.7.
6. Once the left and right glass clips are installed, engage the bottom clips by inserting the glass clip tool at a sharp downward angle to get between the gap between the glass frame and the front bottom fireplace lip. Engage all bottom glass clips. See Figure 11.8.
7. Return glass tool to its shipping location in the lower right corner of the appliance and secure with one screw.

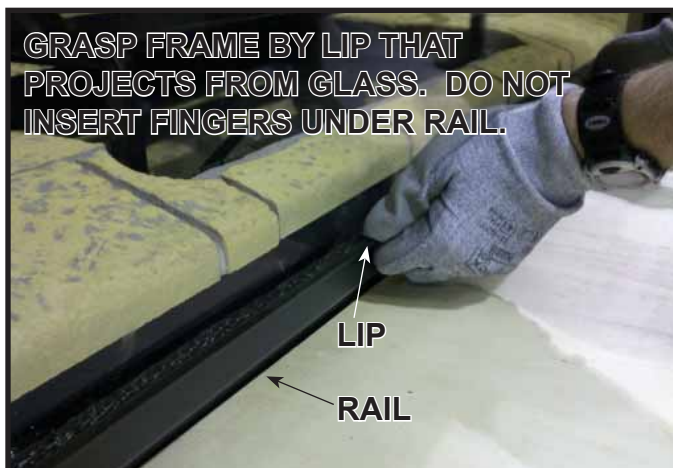

Figure 11.6. Install Glass



Figure 11.7. Fasten Side Glass Clips



Figure 11.8. Fasten Lower Glass Clips

## B. Remove the Shipping Materials

Remove shipping materials from inside or underneath the firebox.

- The splatter guard is a piece of corrugated material used to protect the appliance during the installation process before finishing work on the whole hearth is complete. Splatter guards may be factory installed or accompany the door of the unit, depending on the fireplace model. Splatter guards must be removed before appliance is fired.

**WARNING! Risk of Fire!** Close the ball valve before installing the splatter guard to prevent accidental lighting. Remove the splatter guard before lighting the appliance.

## C. Clean the Appliance

Clean/vacuum any sawdust that may have accumulated inside the firebox or underneath in the control cavity.

## D. Glass Refractory Installation

**CAUTION! Risk of Cuts, Abrasions or Flying Debris.** Wear protective gloves and safety glasses during installation.

**CAUTION! Glass is fragile.** Handle with care.

- Remove rear and side glass retainer brackets as shown in Figure 11.10. Retain fasteners for use in Steps 3-5.
- Locate notch on rear corners of log mount plate for rear glass assembly.
- Place rear glass assembly into notches in appliance and tilt upright into position. While holding glass in position, reattach glass retainer with fasteners saved in Step 1. Do not overtighten.
- Slide left glass assembly into left side of appliance. Attach glass retainer with fasteners saved in Step 1. Do not overtighten. See Figure 10.11.
- Slide right glass assembly into right side of appliance. Attach glass retainer with fasteners saved in Step 1. Do not overtighten.

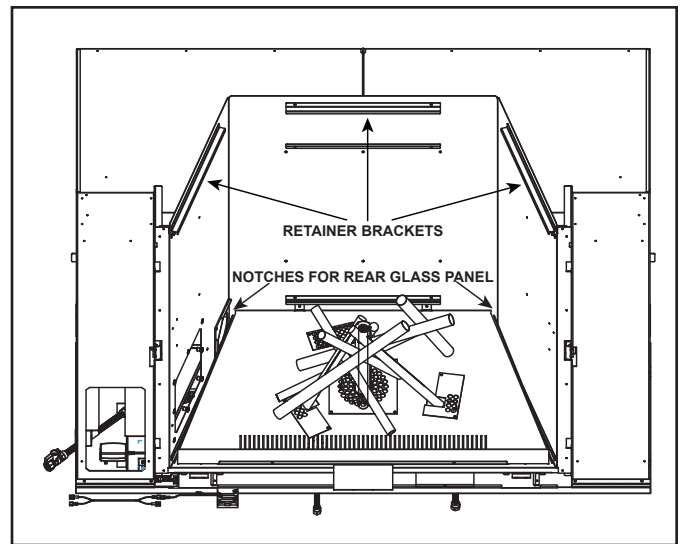

Figure 11.10 Remove Retainer Brackets

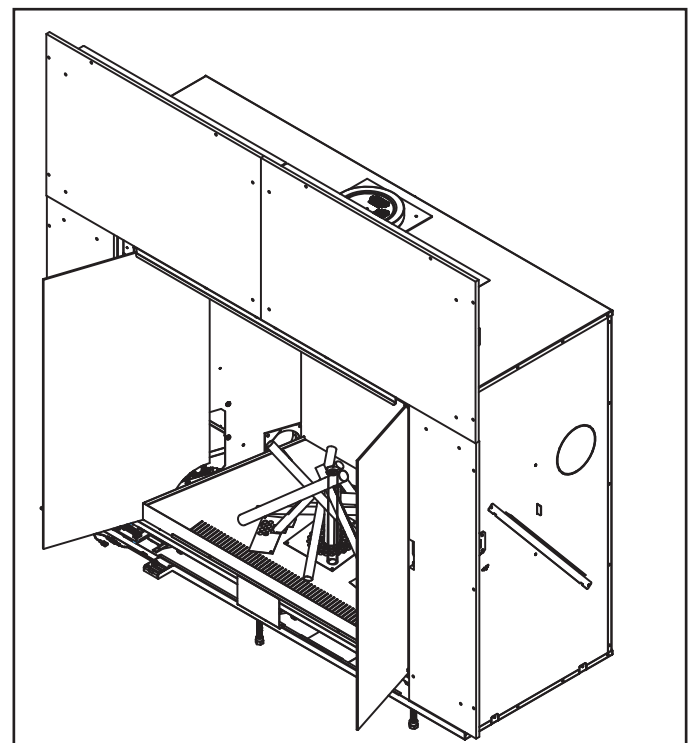

Figure 11.11 Side Panel Installation

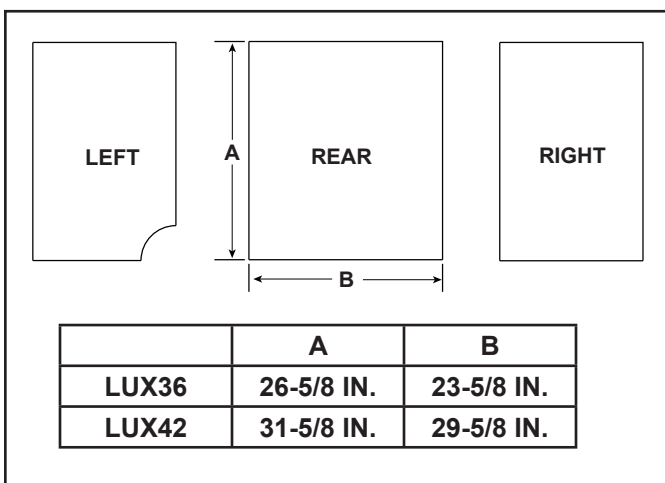

Figure 11.9 Refractory Glass Panels

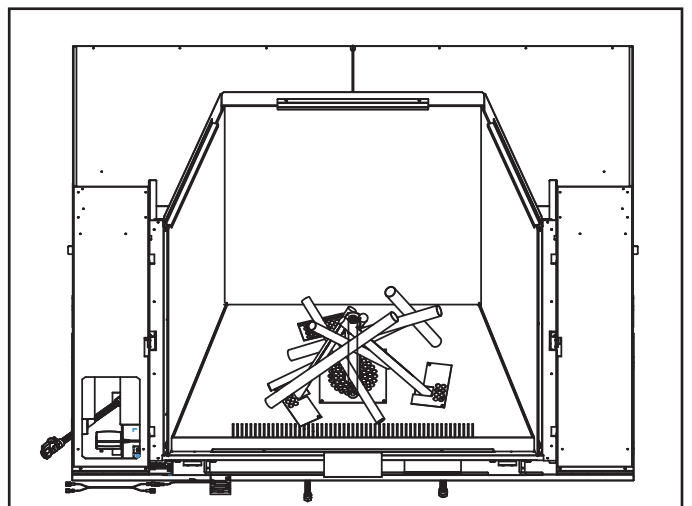

Figure 11.12 Glass Refractory Installed

## E. Media Placement

**WARNING! Choking Hazard!** Keep media out of reach of children.

### **⚠ WARNING**



#### Delayed Ignition Risk

- Place media according to instructions.
- Do NOT place media in area in front of pilot or between burner tracks.
- Do NOT place media in a position that they may fall into area in front of pilot.
- Do NOT use any media other than the media supplied with this fireplace.
- Do NOT use more than the amount of media indicated in the instructions per fireplace.

Fireplace will not function properly.  
Delayed ignition may occur.

Do not use more than 20 pounds of media in LUX36 or 24 pounds of media in LUX42. The LUX36 includes two 10 pound bags of media. The LUX42 includes one 10 pound bag and one 14 pound bag of media.

1. Place media evenly on the log mounting plate. See Figure 11.13.
2. When placing media around burner tubes, do not allow media to fall into appliance.



Figure 11.13

3. The LUX36 and LUX42 appliances come with a rock media placement jig installed. See Figure 11.14.



Figure 11.14 Rock Media Jig

4. Use all media supplied with appliance. Once media is properly installed, carefully remove the rock media placement jig. Do not allow any media to fall into the opening. See Figure 11.15. Store the rock media placement jig for later use.



Figure 11.15 Remove Rock Media Jig

## F. Burner Tube Removal

- Disconnect power to appliance.
- Remove media from appliance.
- Remove the "L" plates and inner surround frame.

**Note:** Mark and note burner tube locations. They are not interchangeable. See Figure 11.16.

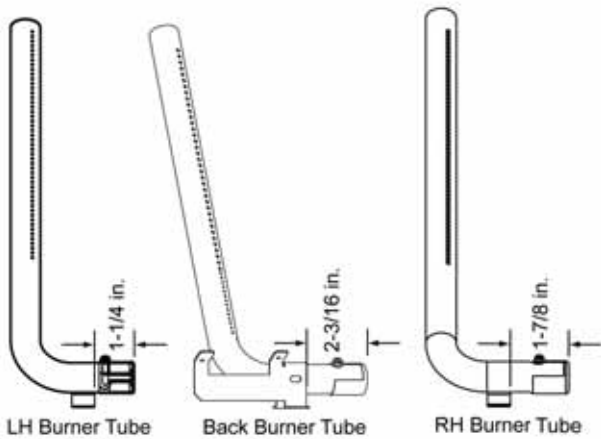
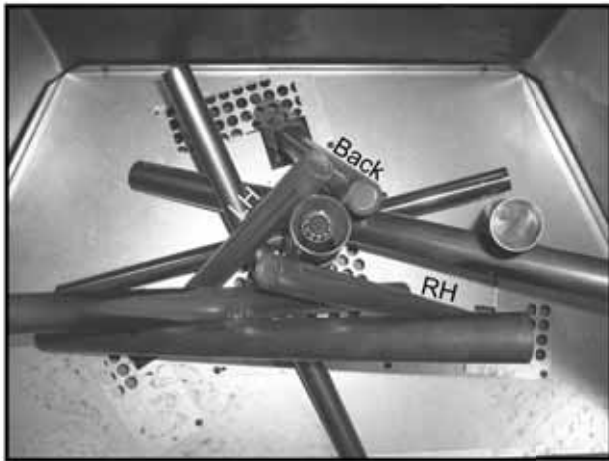

Figure 11.16 Burner Tube Identification

- Remove three cover plates by removing two screws from each plate. See Figure 11.17.

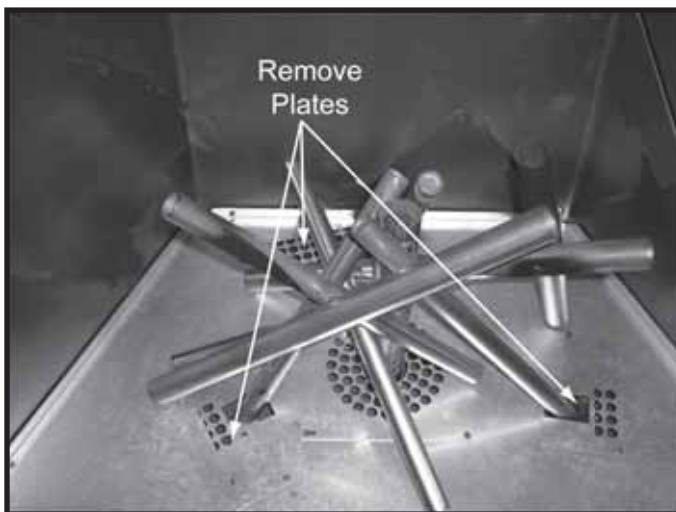

Figure 11.17 Remove Three Plates

- Remove three outside burner tubes by removing two screws on each tube. It will be necessary to remove two screws from the pilot assembly and two screws from the pilot shield on the rear burner tube prior to removal. See Figure 11.18

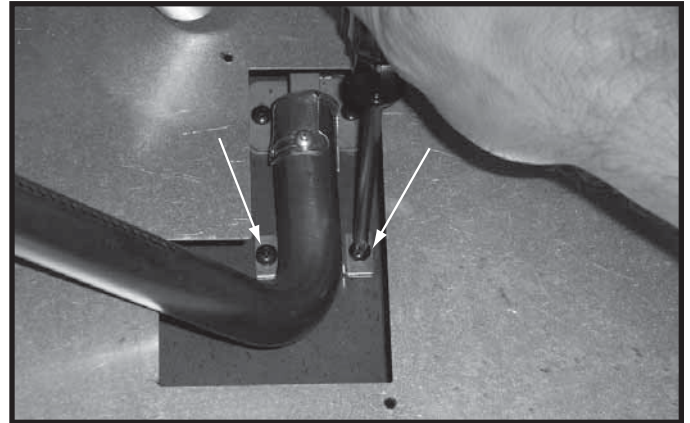

Figure 11.18 Remove Outside Burner Tubes

- Remove decorative steel log assembly by removing 3 screws, lifting up and out. See Figure 11.19.



Figure 11.19 Remove Decorative Steel Log Assembly

- Remove center burner tube by removing two screws. See Figure 11.20.

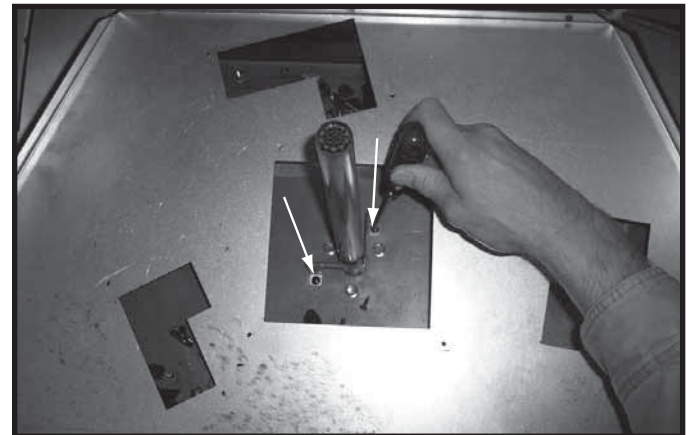

Figure 11.20 Remove Center Burner Tube

- Adjust shutter settings as required.
- Reverse removal procedure to reinstall burner tubes and log assembly.



# 12 Reference Materials

## A. Vent Components Diagrams

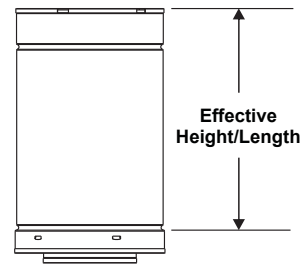

DVP Pipe (see chart)

Pipe	Effective Length	
	Inches	Millimeters
DVP4	4	102
DVP6	6	152
DVP12	12	305
DVP24	24	610
DVP36	36	914
DVP48	48	1219
DVP6A	3 to 6	76 to 152
DVP12A	3 to 12	76 to 305

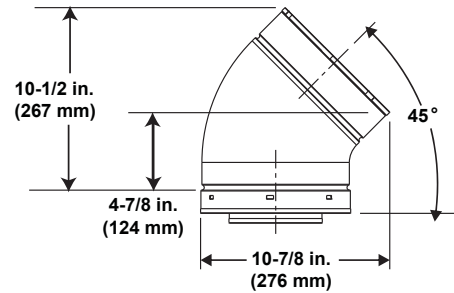

DVP45 (45° Elbow)

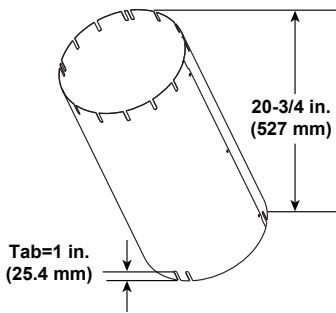

Finished Height: 19-3/4 in./502 mm  
UNIV-AS2 (Attic Insulation Shield)

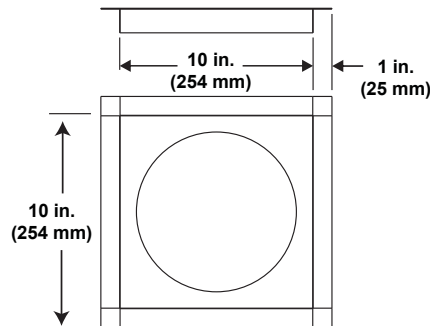

DVP-FS (Ceiling Firestop)

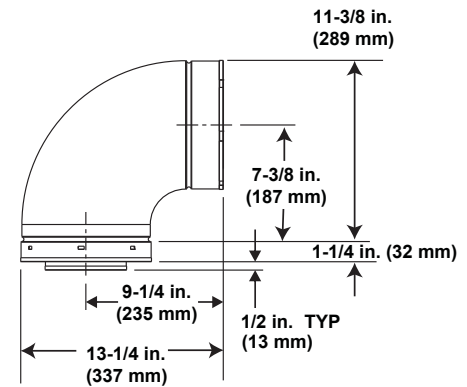

DVP90ST (90° Elbow)

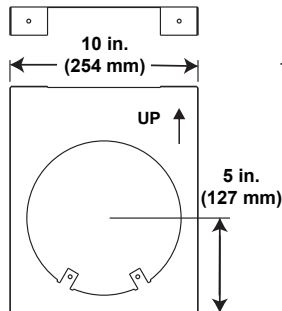

DVP-HVS (Vent Support)

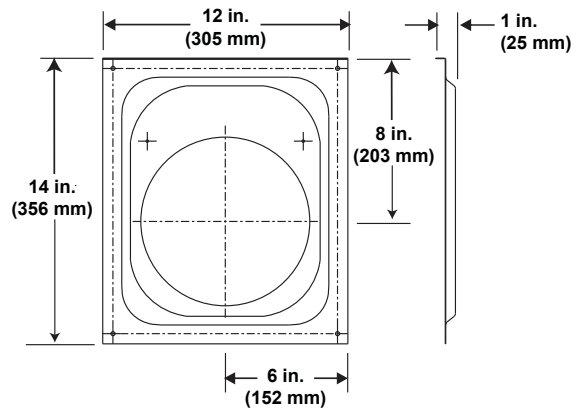
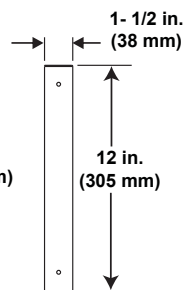

DVP-WS (Wall Shield Firestop)

Figure 12.1 DVP vent components

## A. Vent Components Diagrams (continued)

Note: Heat shields **MUST** overlap by a minimum of 1-1/2 in. (38 mm). **The heat shield is designed to be used on a wall 4 in. to 7-1/4 in. (102 mm to 184 mm) thick.** If wall thickness is less than 4 in. (102 mm) the existing heat shields must be field trimmed. If wall thickness is greater than 7-1/4 in. (184 mm) a DVP-HSM-B will be required.

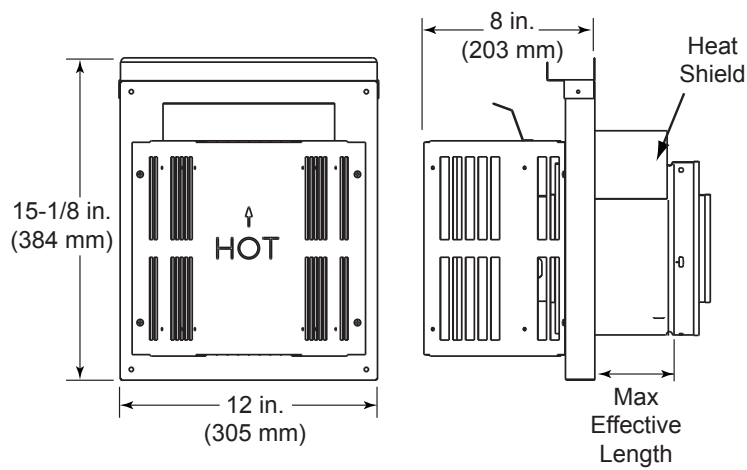

**DVP-TRAP**  
Horizontal Termination Cap

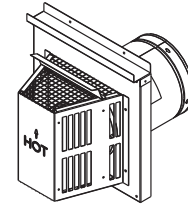

Term Cap	Minimum Effective Length	Maximum Effective Length
Trap1	3-1/8 in.	4-5/8 in.
	79 mm	117 mm
Trap2	5-3/8 in.	9-3/8 in.
	137 mm	238 mm

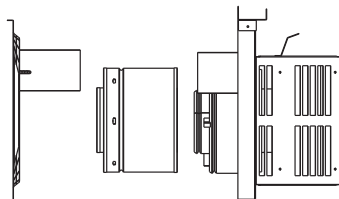

**DVP-TRAP1**

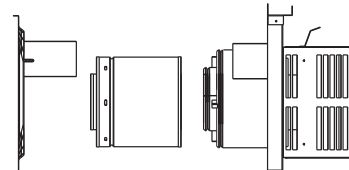

**DVP-TRAP2**

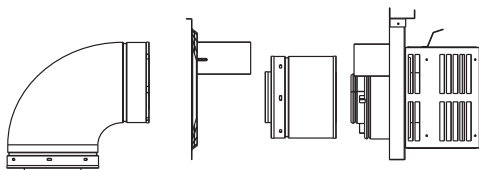

**DVP-TRAPK1**

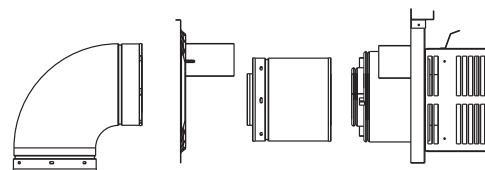

**DVP-TRAPK2**

Figure 12.2 DVP vent components

**A. Vent Components Diagrams (continued)**

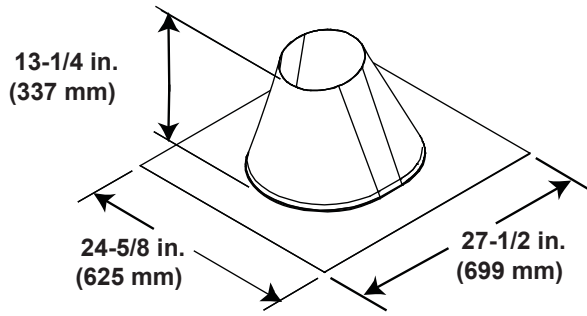

**RF6M**  
Roof Flashing Multi-pak

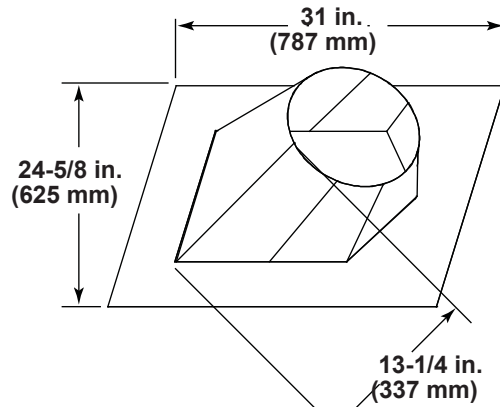

**RF12M**  
Roof Flashing Multi-pak

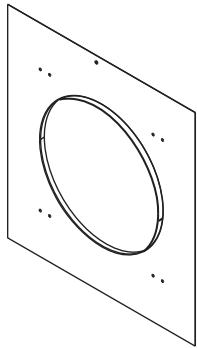

**DVP-TRAPFL**  
Flashing

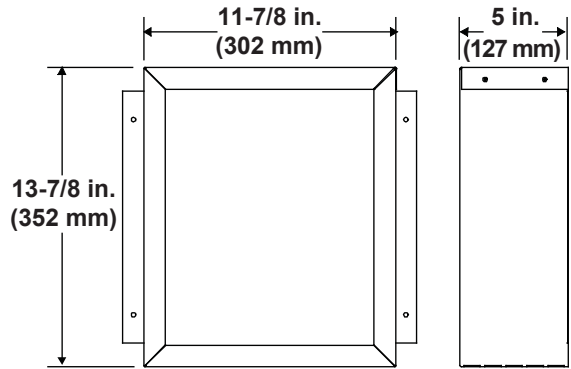

**DVP-BEK2**  
DVP-HPC Cap Brick Extension

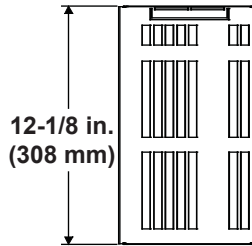
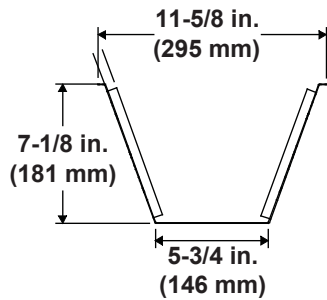

**COOL-ADDM**  
Cap Shield

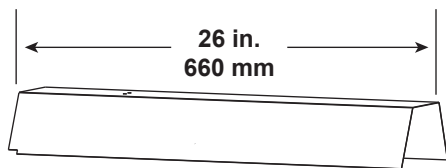
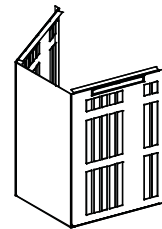

**DVP-HSM-B**  
Extended Heat Shield

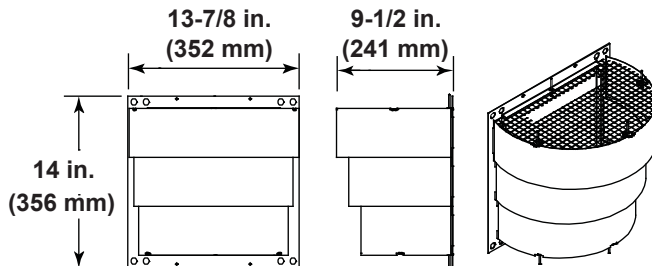

**DRC-RADIUS**  
Cap Shield

Figure 12.3 DVP vent components

## A. Vent Components Diagrams (continued)

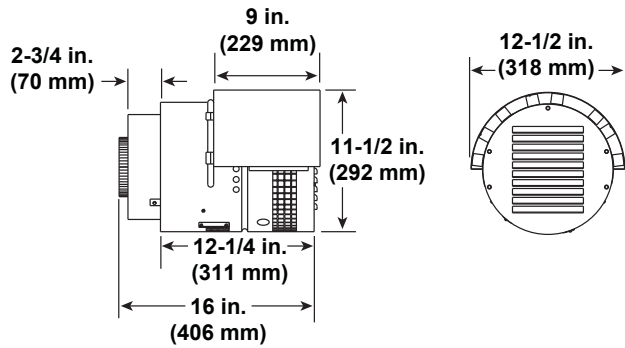

**PVK-80**

(Approved for LUX36 and LUX42.)  
(Installation of PVK80-PLUS Kit required)

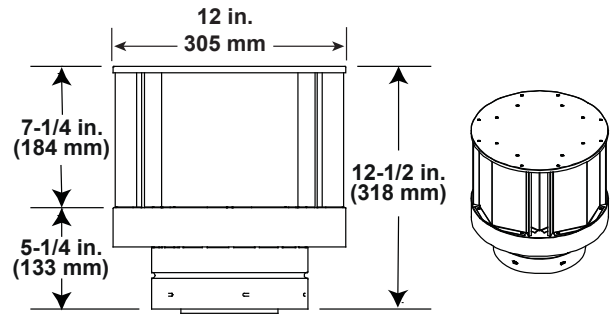

**DVP-TVHW**

Vertical Termination Cap (Highwind)

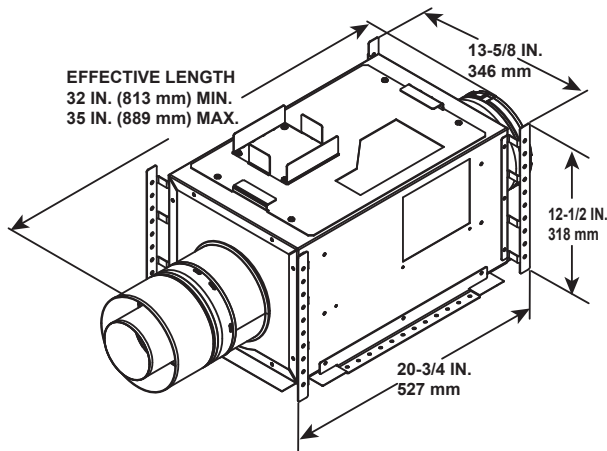

**PVI-SLP**  
Power Vent Inline

Optional Wire Harness	
DESCRIPTION	PART NUMBER
10 ft. PV Wire Harness	PVI-WH10
20 ft. PV Wire Harness	PVI-WH20
40 ft. PV Wire Harness	PVI-WH40
60 ft. PV Wire Harness	PVI-WH60
80 ft. PV Wire Harness	PVI-WH80
100 ft. PV Wire Harness	PVI-WH100

**Note:** Wire harnesses required to power the PVI-SLP connect to the appliance and are ordered separately from PVI-SLP. Contact your dealer to order.

**Note:** Use only approved termination caps with the PVI-SLP. See instructions included with PVI-SLP kit.

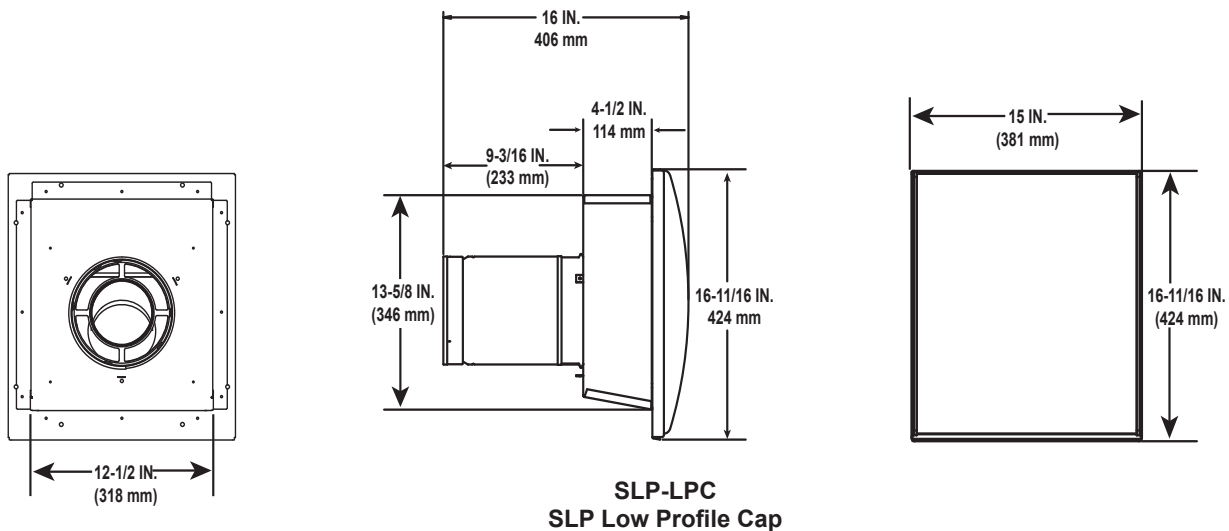

**SLP-LPC**  
SLP Low Profile Cap

Figure 12.5 Vent Components

## **B. Accessories**

Install approved accessories per instructions included with accessories. Contact your dealer for a list of approved accessories.

**WARNING! Risk of Fire and Electric Shock!** Use *ONLY* *Hearth & Home Technologies-approved optional accessories with this appliance. Using non-listed accessories could result in a safety hazard and will void the warranty.*

### **Remote Controls, Wall Controls and Wall Switches**

Follow the instructions supplied with the control installed to operate your fireplace:

For safety:

- Install a switch lock or a wall/remote control with child protection lockout feature.
- Keep remote controls out of reach of children.

See your dealer if you have questions.

### **Optional Heat-Zone® Gas Kit**

Follow the instruction supplied with the kit for operation.

- Preparation for installation of Heat-Zone® Gas Kit is discussed in Section 5.E.

See your dealer if you have questions.

Heat & Glo, a brand of Hearth & Home Technologies Inc.  
7571 215<sup>th</sup> Street West, Lakeville, MN 55044  
[www.heatnglo.com](http://www.heatnglo.com)

Please contact your Heat & Glo dealer with any questions or concerns.  
For the location of your nearest Heat & Glo dealer,  
please visit [www.heatnglo.com](http://www.heatnglo.com).

*Printed in U.S.A. - Copyright 2014*